

# Service Manual

Digital Camera

LUMIX

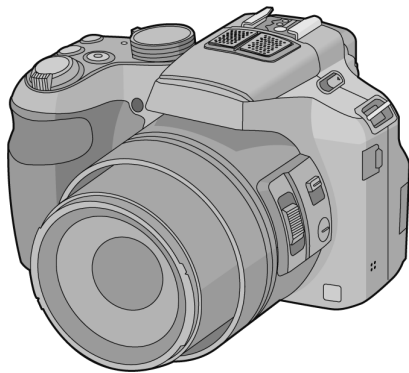

Model No. **DMC-FZ200P**

**DMC-FZ200PC**

**DMC-FZ200PU**

**DMC-FZ200EB**

**DMC-FZ200EE**

**DMC-FZ200EF**

**DMC-FZ200EG**

**DMC-FZ200EP**

**DMC-FZ200GC**

**DMC-FZ200GK**

**DMC-FZ200GN**

**DMC-FZ200GT**

**DMC-FZ200SG**

Colour

(K).....Black Type

## **WARNING**

This service information is designed for experienced repair technicians only and is not designed for use by the general public. It does not contain warnings or cautions to advise non-technical individuals of potential dangers in attempting to service a product. Products powered by electricity should be serviced or repaired only by experienced professional technicians. Any attempt to service or repair the product or products dealt with in this service information by anyone else could result in serious injury or death.

**Panasonic**<sup>®</sup>

© Panasonic Corporation 2012 Unauthorized copying and distribution is a violation of law.

# TABLE OF CONTENTS

	PAGE
<b>1 Safety Precautions</b> .....	<b>3</b>
1.1. General Guidelines .....	3
1.2. Leakage Current Cold Check .....	3
1.3. Leakage Current Hot Check (See Figure. 1) .....	3
1.4. How to Discharge the E.Capacitor on Flash P.C.B. ....	4
<b>2 Warning</b> .....	<b>5</b>
2.1. Prevention of Electrostatic Discharge (ESD) to Electrostatically Sensitive (ES) Devices .....	5
2.2. How to Recycle the Lithium Ion Battery (U.S. Only) .....	5
2.3. Caution for AC Cord(For EB/GC) .....	6
2.4. How to Replace the Lithium Battery .....	7
<b>3 Service Navigation</b> .....	<b>8</b>
3.1. Introduction .....	8
3.2. Important Notice .....	8
3.3. General Description About Lead Free Solder (PbF) .....	9
3.4. How to Define the Model Suffix (NTSC or PAL model) .....	10
<b>4 Specifications</b> .....	<b>14</b>
<b>5 Location of Controls and Components</b> .....	<b>16</b>
<b>6 Service Mode</b> .....	<b>17</b>
6.1. Error Code Memory Function .....	17
<b>7 Service Fixture &amp; Tools</b> .....	<b>20</b>
7.1. Service Fixture and Tools .....	20
7.2. When Replacing the Main P.C.B. ....	21
7.3. Service Position .....	21
<b>8 Disassembly and Assembly Instructions</b> .....	<b>22</b>
8.1. Disassembly Flow Chart .....	22
8.2. P.C.B. Location .....	22
8.3. Disassembly Procedure .....	23
8.4. Lens Disassembly Procedure .....	35
8.5. Removal of the MOS Unit .....	42
<b>9 Measurements and Adjustments</b> .....	<b>44</b>
9.1. Introduction .....	44
9.2. Before Disassembling the unit .....	44
9.3. Details of Electrical Adjustment .....	46
9.4. After Adjustment .....	50
<b>10 Maintenance</b> .....	<b>51</b>
10.1. Cleaning Lens, Viewfinder and LCD Panel .....	51
<b>11 Block Diagram</b> .....	<b>52</b>
11.1. Overall Block Diagram .....	52
11.2. System Control Block Diagram .....	53
11.3. Video/Audio Process Block Diagram .....	54
11.4. Lens/Flash Block Diagram .....	55
11.5. Power Block Diagram .....	56
<b>12 Wiring Connection Diagram</b> .....	<b>57</b>
12.1. Interconnection Diagram .....	57

PAGE

# 1 Safety Precautions

## 1.1. General Guidelines

### 1. IMPORTANT SAFETY NOTICE

There are special components used in this equipment which are important for safety. These parts are marked by

⚠ in the Schematic Diagrams, Circuit Board Layout, Exploded Views and Replacement Parts List. It is essential that these critical parts should be replaced with manufacturer's specified parts to prevent X-RADIATION, shock, fire, or other hazards. Do not modify the original design without permission of manufacturer.

2. An Isolation Transformer should always be used during the servicing of AC Adaptor whose chassis is not isolated from the AC power line. Use a transformer of adequate power rating as this protects the technician from accidents resulting in personal injury from electrical shocks. It will also protect AC Adaptor from being damaged by accidental shorting that may occur during servicing.
3. When servicing, observe the original lead dress. If a short circuit is found, replace all parts which have been overheated or damaged by the short circuit.
4. After servicing, see to it that all the protective devices such as insulation barriers, insulation papers shields are properly installed.
5. After servicing, make the following leakage current checks to prevent the customer from being exposed to shock hazards.

## 1.2. Leakage Current Cold Check

1. Unplug the AC cord and connect a jumper between the two prongs on the plug.
2. Measure the resistance value, with an ohmmeter, between the jumpered AC plug and each exposed metallic cabinet part on the equipment such as screwheads, connectors, control shafts, etc. When the exposed metallic part has a return path to the chassis, the reading should be between  $1\text{ M}\Omega$  and  $5.2\text{ M}\Omega$ . When the exposed metal does not have a return path to the chassis, the reading must be infinity.

## 1.3. Leakage Current Hot Check (See Figure. 1)

1. Plug the AC cord directly into the AC outlet. Do not use an isolation transformer for this check.
2. Connect a  $1.5\text{ k}\Omega$ ,  $10\text{ W}$  resistor, in parallel with a  $0.15\text{ }\mu\text{F}$  capacitor, between each exposed metallic part on the set and a good earth ground, as shown in Figure. 1.
3. Use an AC voltmeter, with  $1\text{ k}\Omega/\text{V}$  or more sensitivity, to measure the potential across the resistor.
4. Check each exposed metallic part, and measure the voltage at each point.
5. Reverse the AC plug in the AC outlet and repeat each of the above measurements.
6. The potential at any point should not exceed  $0.75\text{ V RMS}$ . A leakage current tester (Simpson Model 229 or equivalent) may be used to make the hot checks, leakage current must not exceed  $1/2\text{ mA}$ . In case a measurement is outside of the limits specified, there is a possibility of a shock hazard, and the equipment should be repaired and rechecked before it is returned to the customer.

Hot-Check Circuit

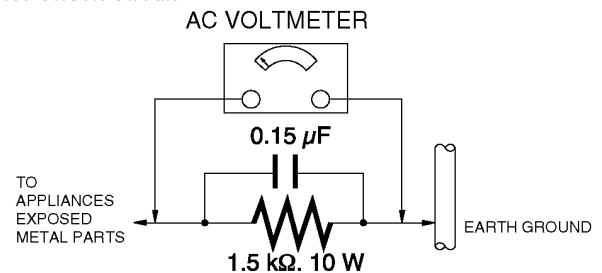

Figure. 1

## 1.4. How to Discharge the E.Capacitor on Flash P.C.B.

### CAUTION:

1. Be sure to discharge the E.Capacitor on FLASH P.C.B..
2. Be careful of the high voltage circuit on FLASH P.C.B. when servicing.

### [Discharging Procedure]

1. Refer to the disassemble procedure and remove the necessary parts/unit.
2. Install the insulation tube onto the lead part of resistor (ERG5SJ102:1k $\Omega$  /5W).  
(An equivalent type of resistor may be used.)
3. Place a resistor between both terminals of E.Capacitor on the FLASH P.C.B. for approx. 5 seconds.
4. After discharging, confirm that the E.Capacitor voltage is lower than 10V by using a voltmeter.

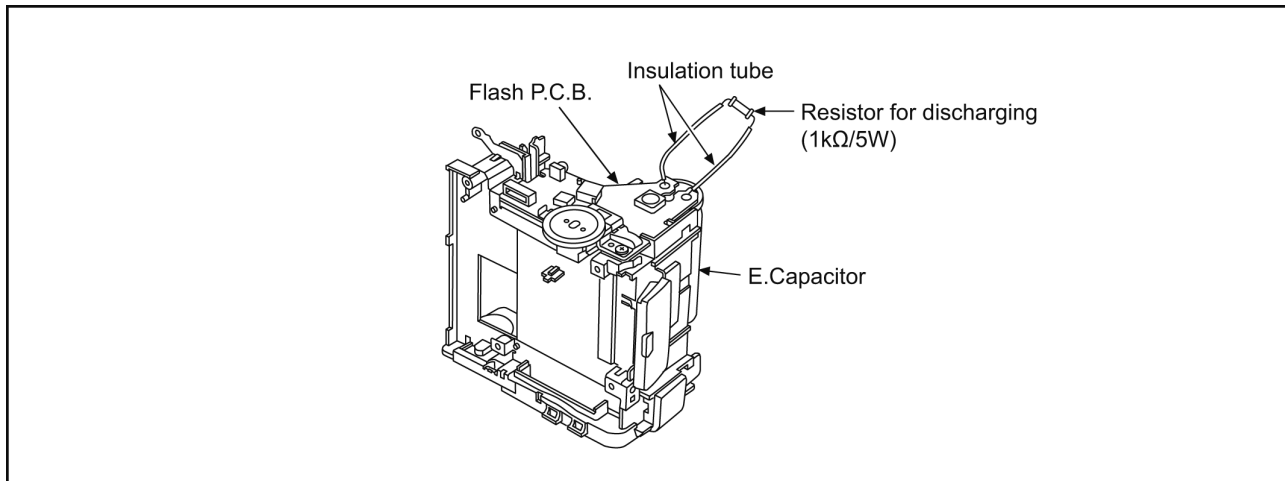

Fig. F1

## 2 Warning

### 2.1. Prevention of Electrostatic Discharge (ESD) to Electrostatically Sensitive (ES) Devices

Some semiconductor (solid state) devices can be damaged easily by static electricity. Such components commonly are called Electrostatically Sensitive (ES) Devices.

Examples of typical ES devices are IC (integrated circuits) and some field-effect transistors and semiconductor "chip" components.

The following techniques should be used to help reduce the incidence of component damage caused by electrostatic discharge (ESD).



1. Immediately before handling any semiconductor component or semiconductor-equipped assembly, drain off any ESD on your body by touching a known earth ground. Alternatively, obtain and wear a commercially available discharging ESD wrist strap, which should be removed for potential shock reasons prior to applying power to the unit under test.
2. After removing an electrical assembly equipped with ES devices, place the assembly on a conductive surface such as aluminum foil, to prevent electrostatic charge buildup or exposure of the assembly.
3. Use only a grounded-tip soldering iron to solder or unsolder ES devices.
4. Use only an antistatic solder removal device. Some solder removal devices not classified as "antistatic (ESD protected)" can generate electrical charge sufficient to damage ES devices.
5. Do not use freon-propelled chemicals. These can generate electrical charges sufficient to damage ES devices.
6. Do not remove a replacement ES device from its protective package until immediately before you are ready to install it. (Most replacement ES devices are packaged with leads electrically shorted together by conductive foam, aluminum foil or comparable conductive material).
7. Immediately before removing the protective material from the leads of a replacement ES device, touch the protective material to the chassis or circuit assembly into which the device will be installed.

**CAUTION :**

Be sure no power is applied to the chassis or circuit, and observe all other safety precautions.

8. Minimize bodily motions when handling unpackaged replacement ES devices. (Otherwise harmless motion such as the brushing together of your clothes fabric or the lifting of your foot from a carpeted floor can generate static electricity (ESD) sufficient to damage an ES device).

### 2.2. How to Recycle the Lithium Ion Battery (U.S. Only)

<b>ENGLISH</b>		A lithium ion battery that is recyclable powers the product you have purchased. Please call 1-800-8-BATTERY for information on how to recycle this battery.
<b>FRANÇAIS</b>		L'appareil que vous vous êtes procuré est alimenté par une batterie au lithium-ion recyclable. Pour des renseignements sur le recyclage de la batterie, veuillez composer le 1-800-8-BATTERY.

## 2.3. Caution for AC Cord (For EB/GC)

### 2.3.1. Information for Your Safety

#### IMPORTANT

Your attention is drawn to the fact that recording of pre-recorded tapes or discs or other published or broadcast material may infringe copyright laws.

#### WARNING

To reduce the risk of fire or shock hazard, do not expose this equipment to rain or moisture.

#### CAUTION

To reduce the risk of fire or shock hazard and annoying interference, use the recommended accessories only.

#### FOR YOUR SAFETY

##### DO NOT REMOVE THE OUTER COVER

To prevent electric shock, do not remove the cover. No user serviceable parts inside. Refer servicing to qualified service personnel.

### 2.3.2. Caution for AC Mains Lead

For your safety, please read the following text carefully.

This appliance is supplied with a moulded three-pin mains plug for your safety and convenience.

A 5-ampere fuse is fitted in this plug.

Should the fuse need to be replaced please ensure that the replacement fuse has a rating of 5 amperes and it is approved by ASTA or BSI to BS1362.

Check for the ASTA mark or the BSI mark on the body of the fuse.



If the plug contains a removable fuse cover you must ensure that it is refitted when the fuse is replaced.

If you lose the fuse cover, the plug must not be used until a replacement cover is obtained.

A replacement fuse cover can be purchased from your local Panasonic Dealer.

If the fitted moulded plug is unsuitable for the socket outlet in your home then the fuse should be removed and the plug cut off and disposed of safely.

There is a danger of severe electrical shock if the cut off plug is inserted into any 13-ampere socket.

If a new plug is to be fitted please observe the wiring code as shown below.

If in any doubt, please consult a qualified electrician.

### 2.3.2.1. Important

The wires in this mains lead are coloured in accordance with the following code:

Blue	Neutral
Brown	Live

As the colours of the wires in the mains lead of this appliance may not correspond with the coloured markings identifying the terminals in your plug, proceed as follows:

The wire which is coloured BLUE must be connected to the terminal in the plug which is marked with the letter N or coloured BLACK.

The wire which is coloured BROWN must be connected to the terminal in the plug which is marked with the letter L or coloured RED.

Under no circumstances should either of these wires be connected to the earth terminal of the three pin plug, marked with the letter E or the Earth Symbol.

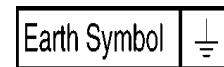

### 2.3.2.2. Before Use

Remove the Connector Cover as follows.

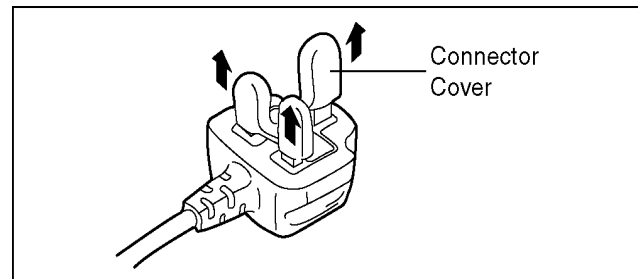

### 2.3.2.3. How to Replace the Fuse

1. Remove the Fuse Cover with a screwdriver.

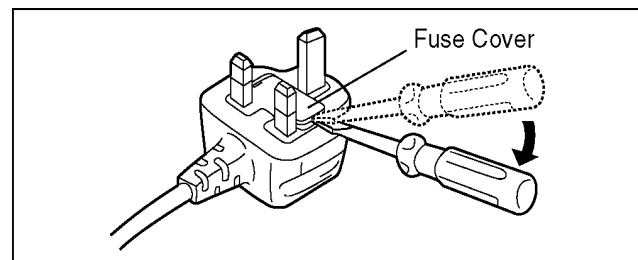

2. Replace the fuse and attach the Fuse cover.

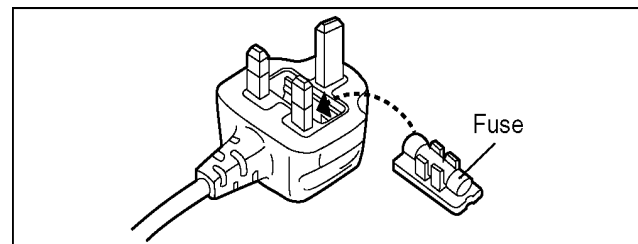

## 2.4. How to Replace the Lithium Battery

### 2.4.1. Replacement Procedure

1. Remove the SUB P.C.B.. (Refer to Disassembly Procedures.)
2. Remove the Lithium battery (Ref. No. "B9301" at foil side of SUB P.C.B.) and then replace it into new one.

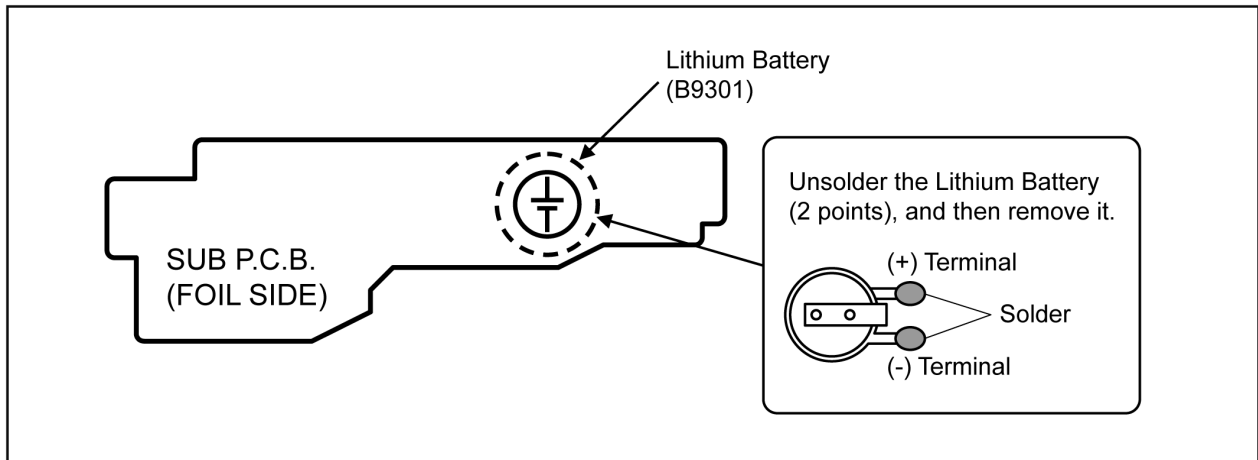

#### NOTE:

This Lithium battery is a critical component.

(Type No.: ML614 **Manufactured by Energy Company, Panasonic Corporation.**)

It must never be subjected to excessive heat or discharge.

It must therefore only be fitted in requirement designed specifically for its use.

Replacement batteries must be of same type and manufacture.

They must be fitted in the same manner and location as the original battery, with the correct polarity contacts observed.

Do not attempt to re-charge the old battery or re-use it for any other purpose.

It should be disposed of in waste products destined for burial rather than incineration.

#### (For English)

##### CAUTION

- Danger of explosion if battery is incorrectly replaced. Replace only with the type recommended by the manufacturer.
- When disposing the batteries, please contact your local authorities or dealer and ask for the correct method of disposal.

#### (For German)

##### ACHTUNG

- Explosionsgefahr bei falschem Anbringen der Batterie. Ersetzen Sie die Batterie nur durch den vom Hersteller empfohlenen Typ.
- Wenden Sie sich zur Entsorgung der Batterien an die lokalen Behörden oder erfragen Sie die richtige Vorgehensweise zur Entsorgung.

#### (For French)

##### MISE EN GARDE

- Il y a un danger d'explosion si la batterie n'est pas correctement remplacée. Remplacez-la uniquement par le type recommandé par le fabricant.
- Pour vous débarrasser des batteries, veuillez contacter les autorités locales ou votre revendeur afin de connaître la procédure d'élimination à suivre.

#### NOTE:

Above caution is applicable for a battery pack which is for DMC-FZ200 series, as well.

## 3 Service Navigation

### 3.1. Introduction

This service manual contains technical information, which allow service personnel's to understand and service this model.

Please place orders using the parts list and not the drawing reference numbers.

If the circuit is changed or modified, the information will be followed by service manual to be controlled with original service manual.

### 3.2. Important Notice

#### 3.2.1. About lens block

- The image sensor (MOS) unit which are connected to the lens unit with 4 screws. These screws are locked with the screw locking glue, after performing the Optical tilt adjustment.

During servicing, if one of MOS unit fixing screws are loosened, the Optical tilt adjustment must be performed.

(About the Optical tilt adjustment, refer to the "9.3.2. Adjustment Specifications" for details.)

#### NOTE:

- It is necessary to use the "DSC\_Tilt" software to allow the "Optical tilt adjustment".
- The Adjustment software "DSC\_Tilt" is available at "TSN Website".

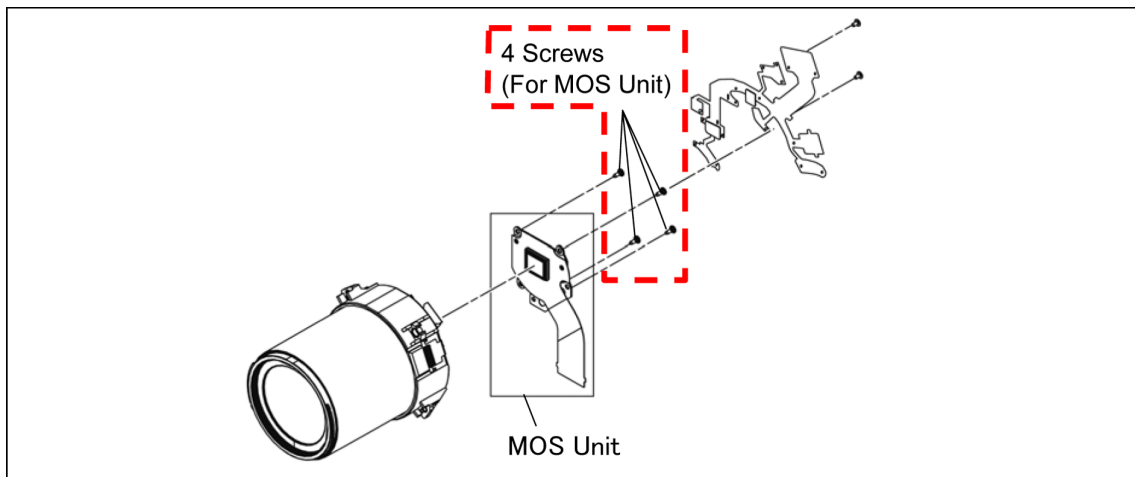

#### 3.2.2. About VENUS ENGINE(IC6001) [Located on the Main P.C.B.]:

- The VENUS ENGINE (IC6001) consists of two IC chips, which are fixed together with solder. (The so called, "Package On Package" type IC.)

#### NOTE:

- During servicing, do not press down hard on the surface of IC6001.

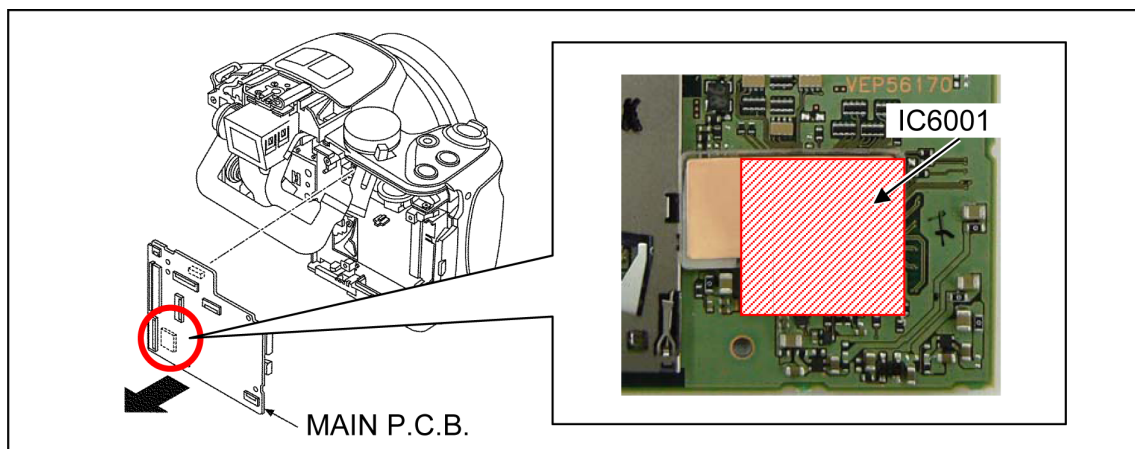

#### 3.2.3. About Flexible Cable and Connector

Do not touch carelessly so that the foreign body should not adhere to the terminal part of flexible cable and connector.

Wipe off with a clean cloth and the cotton bud, etc. when the terminal part is dirty.



### 3.3. General Description About Lead Free Solder (PbF)

The lead free solder has been used in the mounting process of all electrical components on the printed circuit boards used for this equipment in considering the globally environmental conservation.

The normal solder is the alloy of tin (Sn) and lead (Pb). On the other hand, the lead free solder is the alloy mainly consists of tin (Sn), silver (Ag) and Copper (Cu), and the melting point of the lead free solder is higher approx.30°C (86°F) more than that of the normal solder.

#### Distinction of P.C.B. Lead Free Solder being used

The letter of "PbF" is printed either foil side or components side on the P.C.B. using the lead free solder.(See right figure)	PbF
--	-----

#### Service caution for repair work using Lead Free Solder (PbF)

- The lead free solder has to be used when repairing the equipment for which the lead free solder is used.  
(Definition: The letter of "PbF" is printed on the P.C.B. using the lead free solder.)
- To put lead free solder, it should be well molten and mixed with the original lead free solder.
- Remove the remaining lead free solder on the P.C.B. cleanly for soldering of the new IC.
- Since the melting point of the lead free solder is higher than that of the normal lead solder, it takes the longer time to melt the lead free solder.
- Use the soldering iron (more than 70W) equipped with the temperature control after setting the temperature at 350±30°C (662±86°F).

#### Recommended Lead Free Solder (Service Parts Route.)

- The following 3 types of lead free solder are available through the service parts route.  
RFKZ03D01KS------(0.3mm 100g Reel)  
RFKZ06D01KS------(0.6mm 100g Reel)  
RFKZ10D01KS------(1.0mm 100g Reel)

#### Note

\* Ingredient: tin (Sn) 96.5%, silver (Ag) 3.0%, Copper (Cu) 0.5%, Cobalt (Co) / Germanium (Ge) 0.1 to 0.3%

### 3.4. How to Define the Model Suffix (NTSC or PAL model)







There are eight kinds of DMC-FZ200.

- a) DMC-FZ200 (Japan domestic model), DMC-FZ200SG
- b) DMC-FZ200P/PC
- c) DMC-FZ200EB/EF/EG/EP
- d) DMC-FZ200EE
- e) DMC-FZ200GT
- f) DMC-FZ200GK
- g) DMC-FZ200GN
- h) DMC-FZ200GC/PU

What is the difference is that the "INITIAL SETTINGS" data which is stored in Flash-ROM mounted on MAIN P.C.B..

#### 3.4.1. Defining methods:

To define the model suffix to be serviced, refer to the nameplate which is putted on the bottom side of the Unit.

<p><b>a) DMC-FZ200 (Japan domestic model), DMC-FZ200SG</b> The nameplate for these models show the following Safety registration mark.</p> 
<p><b>b) DMC-FZ200P/PC</b> The nameplate for these models show the following Safety registration mark.</p> 
<p><b>c) DMC-FZ200EB/EF/EG/EP</b> The nameplate for these models show the following Safety registration mark.</p> 
<p><b>d) DMC-FZ200EE</b> The nameplate for this model shows the following Safety registration mark.</p> 
<p><b>e) DMC-FZ200GT</b> The nameplate for this model shows the following Safety registration mark.</p> 
<p><b>f) DMC-FZ200GK</b> The nameplate for this model shows the following Safety registration mark.</p> 
<p><b>g) DMC-FZ200GN</b> The nameplate for this model shows the following Safety registration mark.</p> 
<p><b>h) DMC-FZ200GC/PU</b> The nameplate for these models do not show any above Safety registration mark.</p>

#### NOTE:

After replacing the MAIN P.C.B., be sure to achieve adjustment.  
The service software is available at "TSN Website".

### 3.4.2. INITIAL SETTINGS:

After replacing the MAIN P.C.B., make sure to perform the initial settings after achieving the adjustment by ordering the following procedure in accordance with model suffix of the unit.

#### 1. IMPORTANT NOTICE:

Before proceeding Initial settings, make sure to read the following CAUTIONS.

### CAUTION 1:(INITIAL SETTINGS)

--- AFTER REPLACING THE MAIN P.C.B. and/or FLASH-ROM ---

[Except "EG, EF, EB and EP" models]

- \*. The model suffix can be chosen **JUST ONE TIME.**  
(Effective model suffix : "P/PU/GC/GT/GK/EE/GN/PC/SG and NONE(JAPAN)")
- \*. Once one of the model suffix has been chosen, the model suffix lists will not be displayed, thus, it can not be changed.

### CAUTION 2:(Stored picture image data in the unit)

This unit employs "Built-in Memory" for picture image data recording.(Approx.70MB)  
After proceeding "INITIAL SETTINGS", the picture image data stored in the unit is erased.

#### 2. PROCEDURES:

- Precautions: Read the above "CAUTION 1" and "CAUTION 2", carefully.
- Preparation:
  - Attach the Battery or AC Adaptor with a DC coupler to the unit.  
(Since this unit has built-in memory, it can be performed without inserting SD memory card.)
  - Remove the lens cap.
- **Step 1. The temporary cancellation of "INITIAL SETTINGS":**  
Set the mode dial to "[ P ] (Program AE mode)".  
While pressing "[ UP ] of Cursor button" and [ MOTION PICTURE ] button simultaneously, turn the Power on.
- **Step 2. The cancellation of "INITIAL SETTINGS":**  
Press the [ PLAYBACK ] button, then playback the picture.  
Press "[ UP ] of Cursor button" and [ MOTION PICTURE ] button simultaneously, then turn the Power off.  
The LCD displays the " ! " mark before the unit powers down.

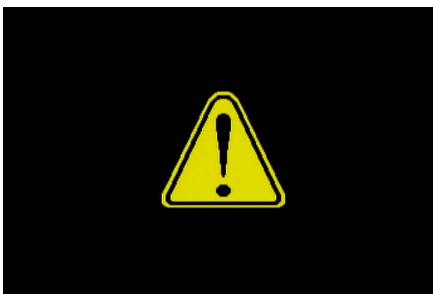

- **Step 3. Turn the Power on:**  
Set the mode dial to "[ P ] (Program AE mode)", and then turn the Power on.
- **Step 4. Display the INITIAL SETTING:**  
While pressing [ MENU/SET ] and "[ RIGHT ] of Cursor buttons" simultaneously, turn the Power off.  
The "INITIAL SETTINGS" menu is displayed.  
There are two kinds of "INITIAL SETTINGS" menu form as follows:

[CASE 1. After replacing MAIN P.C.B.]

[Except "EG, EF, EB and EP" models: (VEP56170A is used as a Main P.C.B.)]

When MAIN P.C.B. has just been replaced, all of the model suffix is displayed as follows. (Four pages in total)

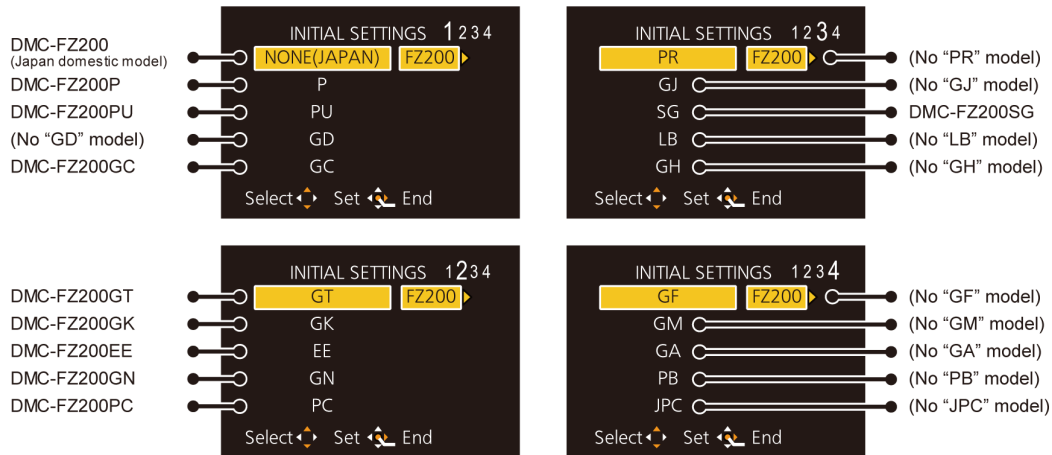

[Only "EG, EF, EB and EP" models: (VEP56170B is used as a Main P.C.B.)]

When MAIN P.C.B. has just been replaced, only 7 model suffix are displayed as follows. (Two pages in total)



[CASE 2. Other than "After replacing MAIN P.C.B."]

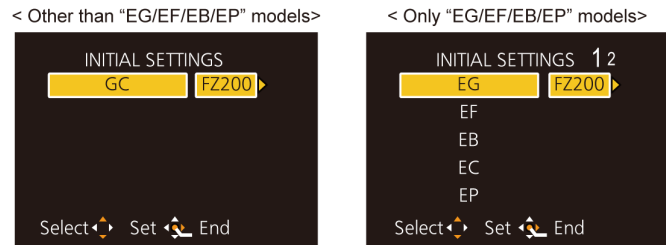

• **Step 5. Choose the model suffix in "INITIAL SETTINGS": (Refer to "CAUTION 1")**

[Caution: After replacing MAIN P.C.B.]

The model suffix can be chosen, **JUST ONE TIME**.

Once one of the model suffix have been chosen, the model suffix lists will not be displayed, thus, it can not be changed.

Therefore, select the area carefully.

Select the area with pressing "[ UP ] / [ DOWN ] of Cursor buttons".

- **Step 6. Set the model suffix in “INITIAL SETTINGS”:**

- Press the “[ RIGHT ] of Cursor buttons”.
- The only set area is displayed, and then press the “[ RIGHT ] of Cursor buttons” after confirmation.  
(The unit is powered off automatically.)

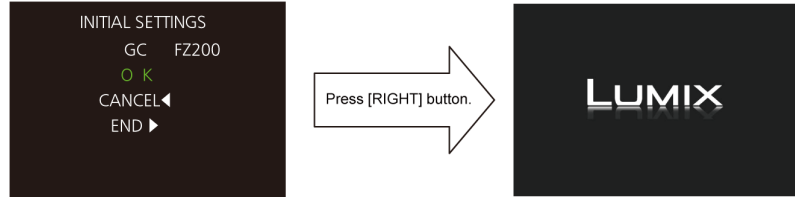

- **Step 7. CONFIRMATION:**

Confirm the display of “PLEASE SET THE CLOCK” in concerned language when the unit is turned on again.  
When the unit is connected to PC with USB cable, it is detected as removable media.

(When the “GT” or “GK” model suffix is selected, the display shows “PLEASE SET THE CLOCK” in Chinese.)

As for your reference, major default setting condition is as shown in the following table.

- **Default setting (After “INITIAL SETTINGS”)**

	MODEL	VIDEO OUTPUT	LANGUAGE	DATE	REMARKS
a)	DMC-FZ200 (Japan domestic model)	NTSC	Japanese	Year/Month/Date	
b)	DMC-FZ200P	NTSC	English	Month/Date/Year	
c)	DMC-FZ200PU	NTSC	Spanish	Month/Date/Year	
d)	DMC-FZ200GC	PAL	English	Date/Month/Year	
e)	DMC-FZ200GT	NTSC	Chinese (traditional)	Year/Month/Date	
f)	DMC-FZ200GK	PAL	Chinese (simplified)	Year/Month/Date	
g)	DMC-FZ200EE	PAL	Russian	Date/Month/Year	
h)	DMC-FZ200GN	PAL	English	Date/Month/Year	
i)	DMC-FZ200PC	NTSC	English	Month/Date/Year	
j)	DMC-FZ200EG	PAL	English	Date/Month/Year	
k)	DMC-FZ200EF	PAL	French	Date/Month/Year	
l)	DMC-FZ200EB	PAL	English	Date/Month/Year	
m)	DMC-FZ200EP	PAL	English	Date/Month/Year	
n)	DMC-FZ200SG	PAL	English	Date/Month/Year	

## 4 Specifications

The following specification is for DMC-FZ200P/DMC-FZ60P.  
Some specifications may differ depending on model suffix.

### Digital Camera:

DMC-FZ200	
<b>Power Source:</b>	DC 8.4 V
<b>Power Consumption:</b>	1.7 W (When recording with LCD Monitor) 1.6 W (When recording with Viewfinder) 1.1 W (When playing back with LCD Monitor) 1.0 W (When playing back with Viewfinder)

DMC-FZ60	
<b>Power Source:</b>	DC 8.4 V
<b>Power Consumption:</b>	1.5 W (When recording with LCD Monitor) 1.4 W (When recording with Viewfinder) 1.0 W (When playing back with LCD Monitor) 0.7 W (When playing back with Viewfinder)

	DMC-FZ200	DMC-FZ60
<b>Camera effective pixels</b>	12,100,000 pixels	16,100,000 pixels
<b>Image sensor</b>	1/2.3" MOS sensor, total pixel number 12,800,000 pixels, Primary color filter	1/2.33" MOS sensor, total pixel number 17,500,000 pixels, Primary color filter
<b>Lens</b> [NANO SURFACE COATING]	Optical 24× zoom, f = 4.5 mm to 108 mm (35 mm film camera equivalent: 25 mm to 600 mm) Wide: F2.8 to F8.0 (when recording motion pictures: F2.8 to F11) Tele: F2.8 to F8.0 (when recording motion pictures: F2.8 to F11)	Optical 24× zoom, f = 4.5 mm to 108 mm (35 mm film camera equivalent: 25 mm to 600 mm) Wide: F2.8 to F8.0 (when recording motion pictures: F2.8 to F11) Tele: F5.2 to F8.0 (when recording motion pictures: F5.2 to F11)
<b>Image Stabilizer</b>	Optical method	

	DMC-FZ200	DMC-FZ60
<b>Focus range</b>		
AF	30 cm (0.98 feet) (Wide)/2 m (6.6 feet) (Tele) to ∞	
AF Macro/ MF/ Intelligent Auto/ Motion Picture	1 cm (0.033 feet) (Wide)/1 m (3.3 feet) (Tele) to ∞	
Scene Mode	There may be differences in the above settings.	
<b>Shutter system</b>	Electronic shutter+Mechanical shutter	
<b>Minimum Illumination</b>	Approx. 9 lx (when i-low light is used, the shutter speed is 1/30th of a second)	
<b>Shutter speed</b>	60 seconds to 1/4000th of a second	4 seconds to 1/2000th of a second
<b>Exposure (AE)</b>	Programme AE (P)/Aperture-Priority AE (A)/Shutter-Priority AE (S)/Manual Exposure (M)	
<b>Metering mode</b>	Multiple/Centre weighted/Spot	
<b>LCD monitor</b>	3.0" TFT LCD (3:2) (Approx. 461,000 dots) (field of view ratio about 100%)	
<b>Viewfinder</b>	Color LCD Viewfinder (Approx. 1,312,000 dots) (field of view ratio about 100%) (with diopter adjustment -5 to +5 diopter)	Colour LCD Viewfinder (Approx. 202,000 dots) (field of view ratio about 100%) (with diopter adjustment -4 to +4 diopter)
<b>Microphone</b>	Stereo	
<b>Speaker</b>	Monaural	

	DMC-FZ200	DMC-FZ60
<b>Recording media</b>	Built-in Memory (Approx. 70 MB)/SD Memory Card/SDHC Memory Card/SDXC Memory Card	
<b>Recording file format</b>		
<b>Still Picture</b>	RAW/JPEG (based on "Design rule for Camera File system", based on "Exif 2.3" standard, DPOF corresponding)/MPO	JPEG (based on "Design rule for Camera File system", based on "Exif 2.3" standard, DPOF corresponding)/MPO
<b>Motion pictures</b>	AVCHD/MP4	
<b>Audio compression format</b>		
AVCHD	Dolby® Digital (2 ch)	
MP4	AAC (2 ch)	
<b>Interface</b>		
<b>Digital</b>	"USB 2.0" (High Speed)	
<b>Analogue video</b>	NTSC	
<b>Audio</b>	Audio line output (monaural)	
<b>Terminal</b>		
<b>[AV OUT/DIGITAL]</b>	Dedicated jack (8 pin)	
<b>[HDMI]</b>	MiniHDMI TypeC	
<b>[MIC/REMOTE]</b>	∅ 2.5 mm jack	—
<b>Dimensions</b> (excluding the projecting parts)	Approx. 125.2 mm (W)× 86.6 mm (H)×110.2 mm (D) [4.9"(W)×3.39"(H)×4.32"(D)]	Approx. 120.3 mm (W)× 80.8 mm (H)×91.9 mm (D) [4.74"(W)×3.18"(H)×3.62"(D)]
<b>Mass (weight)</b>	Approx. 588 g/1.29 lb (with card and battery) Approx. 537 g/1.18 lb (excluding card and battery)	Approx. 493 g/1.09 lb (with card and battery) Approx. 449 g/0.99 lb (excluding card and battery)
<b>Operating temperature</b>	0 °C to 40 °C (32 °F to 104 °F)	
<b>Operating humidity</b>	10%RH to 80%RH	
<b>Language select</b>	[ENGLISH]/[ESPAÑOL]	

#### Battery Charger:

Information for your safety

DMC-FZ200 Panasonic DE-A79B	
<b>Input:</b>	~ 110 V to 240 V, 50/60 Hz, 0.2 A
<b>Output:</b>	=== 8.4 V, 0.65 A

DMC-FZ60 Panasonic DE-A83B	
<b>Input:</b>	~ 110 V to 240 V, 50/60 Hz, 0.15 A
<b>Output:</b>	=== 8.4 V, 0.43 A

#### Equipment mobility:

Movable

#### Battery Pack (lithium-ion):

Information for your safety

DMC-FZ200 Panasonic DMW-BLC12PP	
<b>Voltage/capacity:</b>	7.2 V/1200 mAh

DMC-FZ60 Panasonic DMW-BMB9PP	
<b>Voltage/capacity:</b>	7.2 V/895 mAh

# 5 Location of Controls and Components

The following description is for DMC-FZ200P/DMC-FZ60P.  
Some descriptions may differ depending on model suffix.

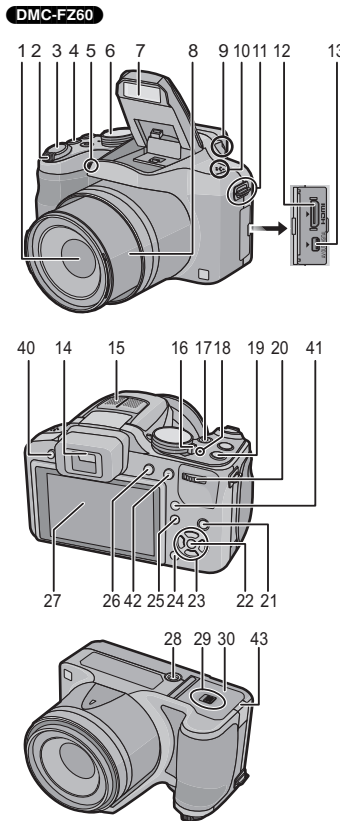
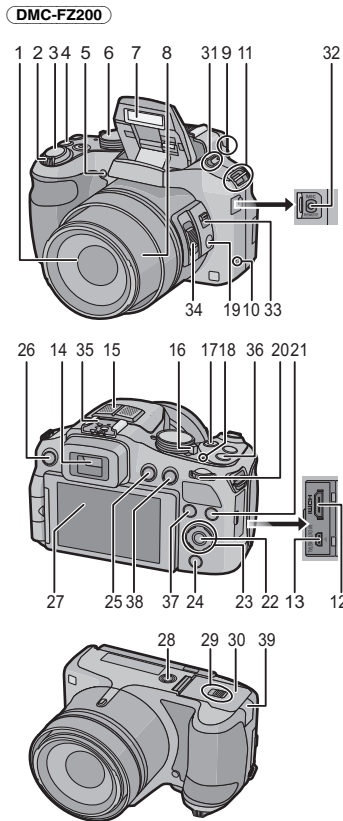

- DMC-FZ200**
- 1 Lens
  - 2 Zoom lever
  - 3 Shutter button
  - 4 (Burst Mode) button
  - 5 Self-timer indicator
  - 6 AF Assist Lamp
  - 7 Mode dial
  - 8 Flash
  - 9 Lens barrel
  - 10 Diopter adjustment dial
  - 11 Speaker
    - Be careful not to cover the speaker with your finger. Doing so may make sound difficult to hear.
  - 12 Shoulder strap eyelet
  - 13 [HDMI] socket
  - 14 [AV OUT/DIGITAL] socket
  - 15 Viewfinder
  - 16 Stereo microphone
  - 17 Camera ON/OFF switch
  - 18 Motion picture button
  - 19 Power lamp
  - 20 [FOCUS] button
  - 21 Rear dial
  - 22 [DISP.] button
  - 23 [MENU/SET] button
  - 24 Cursor buttons
  - 25 [Q.MENU] button/  
 (Delete/Cancel) button
  - 26 [PLAYBACK] button
  - 27 [EVF/LCD] button
  - 28 LCD monitor
  - 29 Tripod mount
    - A tripod with a screw length of 5.5 mm (0.22 inch) or more may damage this unit if attached.
  - 30 Release lever
  - 31 Card/Battery door

- DMC-FZ200**
- 31 Flash open lever
    - To close, push the top of the flash cover until it clicks.
  - 32 [MIC/REMOTE] socket
  - 33 Focus selector switch
  - 34 Side lever
  - 35 Hot shoe
  - 36 [Fn1] button
  - 37 [Fn3] button
  - 38 [AF/AE LOCK] button/[Fn2] button
  - 39 DC coupler cover
    - When using an AC adaptor, ensure that the Panasonic DC coupler (DMW-DCC8: optional) and AC adaptor (DMW-AC8PP: optional) are used.
    - Always use a genuine Panasonic AC adaptor (DMW-AC8PP: optional).

- DMC-FZ60**
- 40 Flash open button
  - 41 [AF/AF-ON/MF] button
  - 42 [AF/AE LOCK] button/[Fn1] button
  - 43 DC coupler cover
    - When using an AC adaptor, ensure that the Panasonic DC coupler (DMW-DCC6: optional) and AC adaptor (DMW-AC8PP: optional) are used.
    - Always use a genuine Panasonic AC adaptor (DMW-AC8PP: optional).



# 6 Service Mode

## 6.1. Error Code Memory Function

### 1. General description

This unit is equipped with history of error code memory function, and can be memorized 16 error codes in sequence from the latest. When the error is occurred more than 16, the oldest error is overwritten in sequence.

The error code is not memorized when the power supply is shut down forcibly (i.e., when the unit is powered on by the battery, the battery is pulled out) The error code is memorized to FLASH-ROM when the unit has just before powered off.

### 2. How to display

The error code can be displayed by ordering the following procedure:

#### • Preparation:

- Attach the Battery or AC Adaptor with a DC coupler to the unit.  
(Since this unit has built-in memory, it can be performed without inserting SD memory card.)
- Remove the lens cap.

#### • Step 1. The temporary cancellation of "INITIAL SETTINGS":

Set the mode dial to "[ P ] (Program AE mode)".

While pressing "[ UP ] of Cursor button" and [ MOTION PICTURE ] button simultaneously, turn the Power on.

#### • Step 2. Execute the error code display mode:

Press the "[ LEFT ] of Cursor button", [ MENU/SET ] button and [ MOTION PICTURE ] button simultaneously.

The display is changed as shown below when the above buttons are pressed simultaneously.

Normal display → Error code display → Operation history display → Normal display → .....

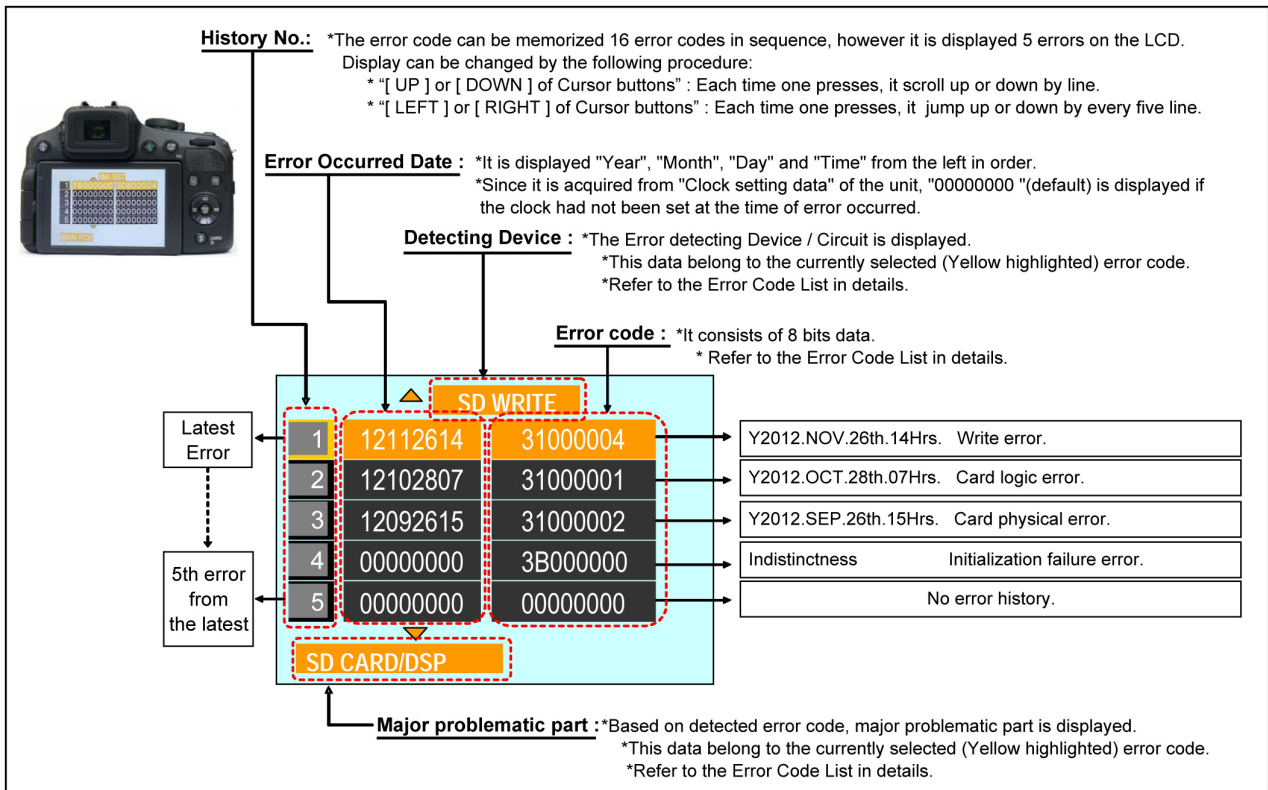

Example of Error Code Display

### 3. Error Code List

The error code consists of 8 bits data and it shows the following information.

Attribute	Main item	Sub item	Error code		Contents (Upper line)	Error Indication								
			High 4 bits	Low 4 bits	Problematic Part & Check point (Lower line)	Detecting device	Problematic Part/Circuit							
LENS	Lens drive	OIS	18*0	1000	PSD (X) error. Hall element (X axis) position detect error in OIS unit. OIS Unit	OIS X	LENSu NG							
				2000	PSD (Y) error. Hall element (Y axis) position detect error in OIS unit. OIS Unit	OIS Y								
			3000	GYRO (X) error. Gyro (IC7101: X axis) detect error on MAIN P.C.B.. IC7101 (Gyro element) or IC6001 (VENUS ENGINE)	GYRO X	GYRO NG								
			4000	GYRO (Y) error. Gyro (IC7101: Y axis) detect error on MAIN P.C.B.. IC7101 (Gyro element) or IC6001 (VENUS ENGINE)	GYRO Y									
			6000	Drive voltage (X) error. LENS Unit, LENS flex breaks, IC6001 (VENUS ENGINE) AD value error,	OISX REF	LENSu/LENS FPC								
			7000	Drive voltage (Y) error. LENS Unit, LENS flex breaks, IC6001 (VENUS ENGINE) AD value error,	OISY REF									
			8000	OIS GYRO-Digital communication error IC7101(Gyro element) or IC6001(VENUS ENGINE)	(No indication)	(No indication)								
			Zoom	0710	Collapsible barrel Low detect error (Collapsible barrel encoder always detects Low.) Mechanical lock, FP9005-(1) signal line or IC6001 (VENUS ENGINE)	ZOOM L	ZOOMm/LENSu							
					0720	Collapsible barrel High detect error (Collapsible barrel encoder always detects High.) Mechanical lock, FP9005-(1) signal line or IC6001 (VENUS ENGINE)		ZOOM H						
				0730	Zoom motor sensor error. Mechanical lock, FP9005-(5), (12) signal line or IC6001 (VENUS ENGINE)	ZOOM ENC								
					0740			Zoom motor sensor error. (During monitor mode.) Mechanical lock, FP9005-(5), (12) signal line or IC6001 (VENUS ENGINE)						
				0750	Zoom motor sensor error. (During monitor mode with slow speed.) Mechanical lock, FP9005-(5), (12) signal line or IC6001 (VENUS ENGINE)	(No indication)		(No indication)						
					0760				Detection of zoom misregistration by impact such as falls. Lens Unit					
				Focus	0701	HP Low detect error (Focus encoder always detects High, and not becomes Low) Mechanical lock, FP9005-(19) signal line or IC6001 (VENUS ENGINE)		FOCUS L	LENS FPC/DSP					
						0702		HP High detect error (Focus encoder always detects Low, and not becomes High) Mechanical lock, FP9005-(19) signal line or IC6001 (VENUS ENGINE)		FOCUS H				
			Lens	10*8	0000	Lens cap error Zoom motor.Zoom pulse encoder2	(No indication)	(No indication)						
		18*1			0000	Power ON time out error. Lens drive system	LENS DRV	LENSu						
		18*2			0000	Power OFF time out error. Lens drive system								
		Adj. History	OIS	19*0	2000	OIS adj. Yaw direction amplitude error (small)	OIS ADJ	OIS ADJ						
					3000	OIS adj. Pitch direction amplitude error (small)								
					4000	OIS adj. Yaw direction amplitude error (large)								
					5000	OIS adj. Pitch direction amplitude error (large)								
					8000	OIS adj. Yaw direction off set error								
					9000	OIS adj. Pitch direction off set error								
					A000	OIS adj. Yaw direction gain error								
					B000	OIS adj. Pitch direction gain error								
					C000	OIS adj. Yaw direction position sensor error								
					D000	OIS adj. Pitch direction position sensor error								
					E000	OIS adj. other error								
					HARD	VENUS A/D			Flash	28*0	0000	Flash charging error. IC6001-(C13) signal line or Flash charging circuit	STRB CHG	STRB PCB/FPC
						FLASH ROM (EEPROM Area)			FLASH ROM (EEPROM Area)	2B*0	0001	EEPROM read error IC6005 (FLASH ROM)	FROM RE	FROM
		0002	EEPROM write error IC6005 (FLASH ROM)	FROM WR			FROM							
0005	Firmware version up error Replace the firmware file in the SD memory card.	(No indication)	(No indication)											
SYSTEM	RTC	2C*0	0001	SYSTEM IC initialize failure error Communication between IC6001 (VENUS ENGINE) and IC9101 (SYSTEM)		SYS INIT	MAIN PCB							
SOFT	CPU	Reset	30*0	0001		NMI reset Non Mask-able Interrupt (30000001-30000007 are caused by factors)	NMI RST	MAIN PCB						
				0007										
	CPU, ASIC hard	Stop	38*0	0001		Camera task finish process time out. Communication between Lens system and IC6001 (VENUS ENGINE)	LENS COM	LENSu/DSP						
						0002	Camera task invalid code error. IC6001 (VENUS ENGINE)	DSP	DSP					
				0100		File time out error in recording motion image IC6001 (VENUS ENGINE)								
				0200	File data cue send error in recording motion image IC6001 (VENUS ENGINE)									
				0300	Single or burst recording brake time out.									
				Memory area	3A*0	0008	USB work area partitioning failure USB dynamic memory securing failure when connecting	(No indication)	(No indication)					
	Operation	Power on	3B*0	0000	FLASHROM processing early period of camera during movement.	INIT	(No indication)							
	Zoom	Zoom	3C*0	0000	Inperfect zoom lens processing Zoom lens	ZOOM	ZOOMm/LENSu							
35*0					0000	Software error (0-7bit : command, 8-15bit : status)	DSP	DSP						
35*1			0000	Though record preprocessing is necessary, it is not called.	(No indication)	(No indication)								
35*2			0000	Though record preprocessing is necessary, it is not completed.										

### **Important notice about “Error Code List”**

#### **1) About “\*” indication:**

The third digit from the left is different as follows.

- In case of 0 (example: 18001000)

When the third digit from the left shows “0”, this error occurred under the condition of INITIAL SETTINGS has been completed.

It means that this error is occurred basically at user side.

- In case of 8 (example: 18801000)

When the third digit from the left shows “8”, this error occurred under the condition of INITIAL SETTINGS has been released.

(Example; Factory assembling-line before unit shipment, Service mode etc.)

It means that this error is occurred at service side.

#### **2) About “?” indication: (“18\*0 0?01” to “18\*0 0?50”):**

The third digit from the right shows one of the hexadecimal (“0” to “F”) character.

#### **4. How to exit from Error Code display mode:**

Simply, turn the power off. (Since Error code display mode is executed under the condition of temporary cancellation of “INITIAL SETTINGS”, it wake up with normal condition when turn off the power.)





#### **NOTE:**

The error code can not be initialized.

# 7 Service Fixture & Tools

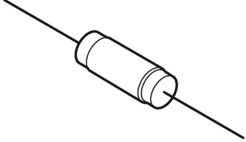
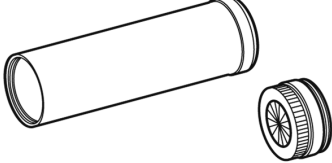
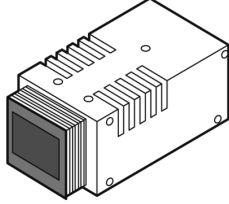
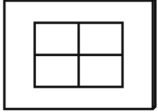
## 7.1. Service Fixture and Tools

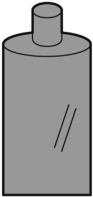
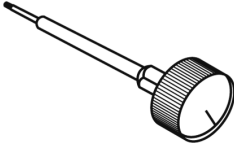
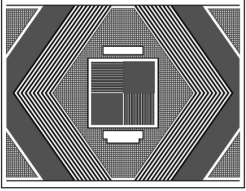
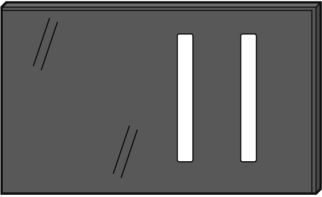
The following Service Fixture and tools are used for checking and servicing this unit.

Resistor for Discharging (1kΩ/5W) <b>ERG5SJ102</b>	Collimator (with Focus Chart) <b>RFKZ0422</b>	LIGHT BOX(with DC Cable) <b>RFKZ0523</b>
 *An equivalent type of Resistor may be used.		 *VFK1164TDVLB can be used.
TR Chart <b>RFKZ0443</b>	Lens Cleaning Kit (BK) <b>VFK1900BK</b>	Grease (for Lens) <b>RFKZ0472</b>
	 *Only supplied 10 set/box.	
Screw locking glue <b>RFKZ0573</b>	Driver (for optical axis adjustment) <b>RFKZ0569</b>	Optical axis adjustment chart <b>RFKZ0570</b>
	 *T4 Torx type	
Camera stand <b>RFKZ0333J</b>	TORQUE DRIVER <b>RFKZ0542</b>	Diffuser <b>RFKZ0591</b>
		

## 7.2. When Replacing the Main P.C.B.

After replacing the MAIN P.C.B., be sure to achieve adjustment.  
The service software is available at "TSN Website".

## 7.3. Service Position

This Service Position is used for checking and replacing parts. Use the following Extension cables for servicing.

Table S1 Extension Cable List

No.	Parts No.	Connection	Form
1	VFK1906	PS9001 (MAIN) - PP8001 (FLASH)	20pin B to B

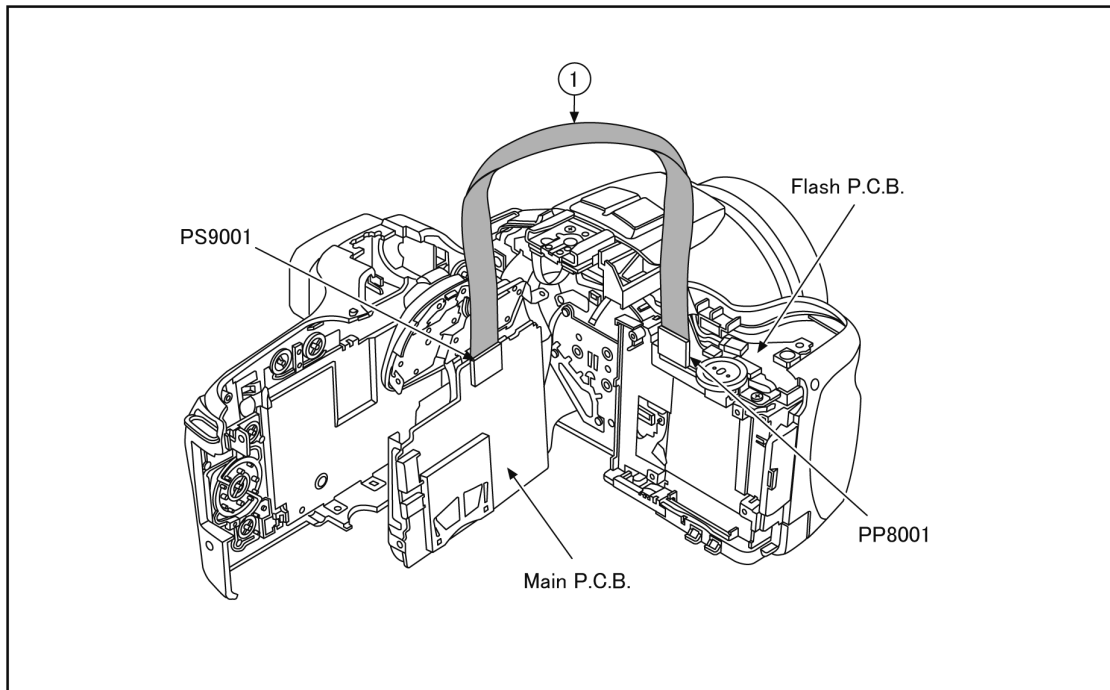

### CAUTION-1. (When servicing FLASH P.C.B.)

1. Be sure to discharge the E.Capacitor on FLASH P.C.B..  
Refer to "HOW TO DISCHARGE THE E.CAPACITOR ON FLASH P.C.B.".  
The E.Capacitor voltage is not lowered soon even if the AC Cord is unplugged or the battery is removed.
2. Be careful of the high voltage circuit on FLASH P.C.B..
3. DO NOT allow other parts to touch the high voltage circuit on FLASH P.C.B..

# 8 Disassembly and Assembly Instructions

## 8.1. Disassembly Flow Chart

This is a disassembling chart.

When assembling, perform this chart conversely.

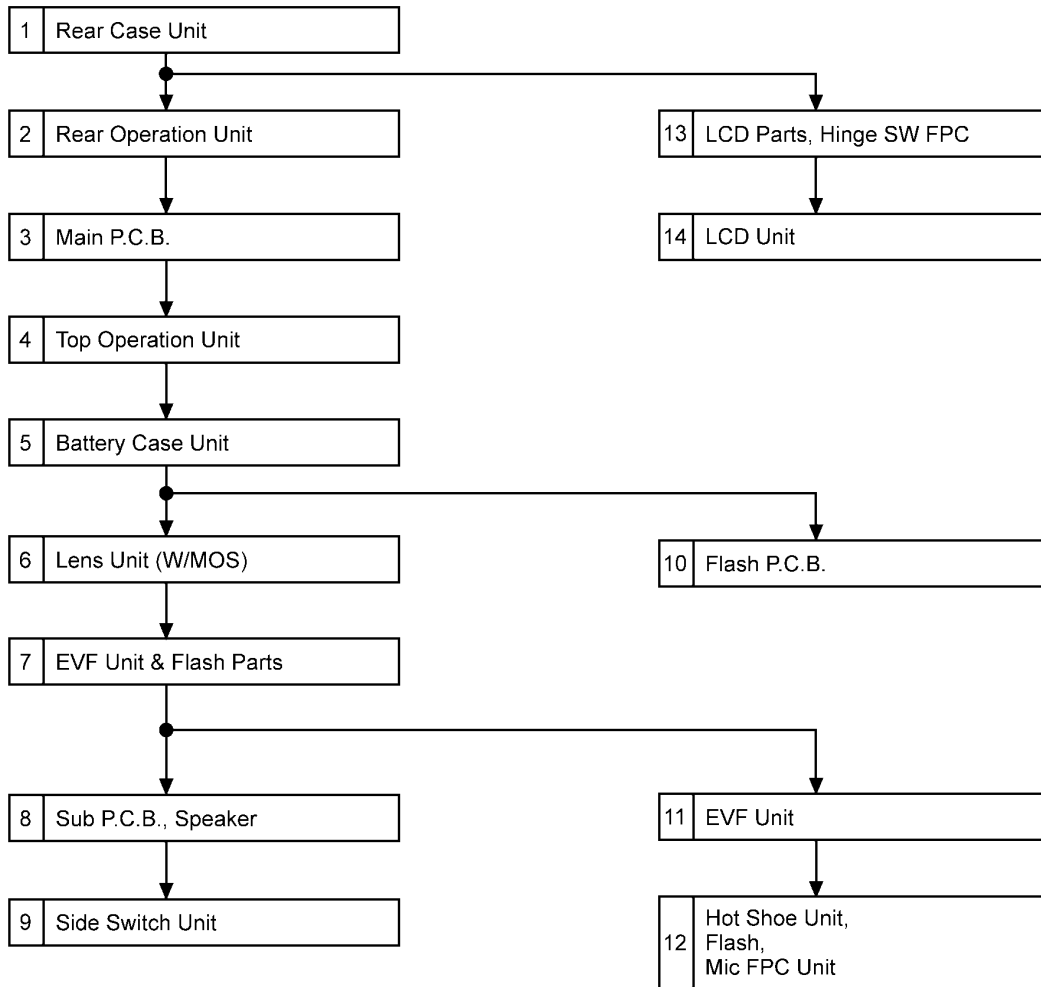

## 8.2. P.C.B. Location

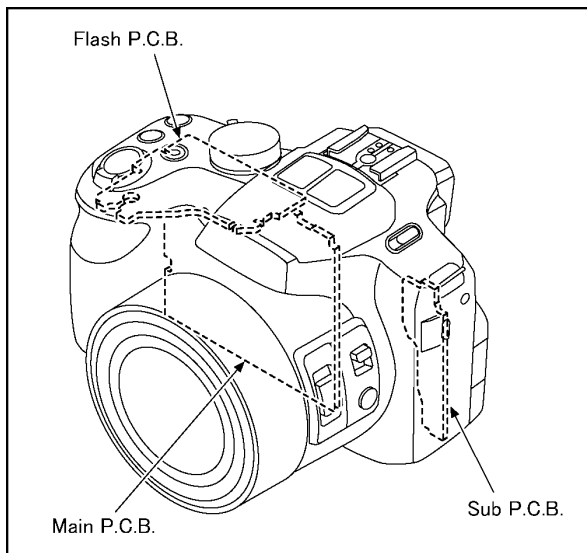

### 8.3. Disassembly Procedure

No.	Item	Fig	Removal			
1	Rear Case Unit	(Fig. D1)	Card			
			Battery			
			3 Screws (A)			
			2 Screws (B)			
		(Fig. D2)	Shoe Spring			
			2 Screws (C)			
			1 Locking tab			
			FP9003 (Flex)			
			Rear Case Unit			
2	Rear Operation Unit	(Fig. D3)	2 Screws (D)			
			2 Hooking parts			
			FP9007 (Flex)			
			Rear Operation Unit			
3	Main P.C.B.	(Fig. D4)	1 Screw (E)			
			FP9001 (Flex)			
			FP9002 (Flex)			
			FP9004 (Flex)			
			FP9005 (Flex)			
			FP9006 (Flex)			
			FP9010 (Flex)			
			PS9001 (Connector)			
			Main P.C.B.			
			1 Hooking part			
			Jack Holder			
			4	Top Operation Unit	(Fig. D5)	1 Screw (F)
						Top Operation Unit
5	Battery Case Unit	(Fig. D6)	P8003 (Connector)			
			P8004 (Connector)			
			1 Screw (G)			
		(Fig. D7)	Battery Case Unit			
6	Lens Unit (W/MOS)	(Fig. D8)	4 Screws (H)			
			Lens Unit (W/MOS)			
7	EVF Unit & Flash Parts	(Fig. D9)	FP9302 (Flex)			
			2 Convexes			
			EVF Unit & Flash Parts			
8	Sub P.C.B. Speaker	(Fig. D10)	1 Screw (I)			
			FP9301 (Flex)			
			1 Rib			
			2 Hooking parts			
			Sub P.C.B.			
			2 Solders			
			Speaker			
9	Side Switch Unit	(Fig. D11)	1 Locking tab			
			Side Frame (R)			
			Strap Holder (R)			
			1 Screw (J)			
			2 Locking tabs			
			Front Heat Sink			
		(Fig. D12)	3 Screws (K)			
			Lens Ring Front			
			2 Convexes			
			Side Switch Unit			
10	Flash P.C.B.	(Fig. D13)	3 Locking tabs			
			Condensor Cover			
		(Fig. D14)	2 Screws (L)			
			2 Locking tabs			
			FP8001 (Flex)			
			Switch Unit			
			1 Hooking part			
Flash P.C.B.						
11	EVF Unit	(Fig. D15)	2 Locking tabs			
			EVF Unit			

No.	Item	Fig	Removal
12	Hot Shoe Unit Flash Mic FPC Unit	(Fig. D16)	1 Hooking part
			1 Screw (M)
		(Fig. D17)	2 Screws (N)
			1 Screw (O)
			2 Locking tabs
			Hot Shoe Unit
			2 Screws (P)
		(Fig. D18)	4 Locking tabs
			Flash Case Top Unit
			Flash Shaft
			2 Convexes
			Flash & Mic FPC Unit
		(Fig. D19)	2 Locking tabs
			Flash Link Cover
			5 Ribs
			1 Positioning Pin
			2 Locking tabs
Flash			
(Fig. D20)	Mic Damper		
	Mic FPC Unit		
	Mic Cushion		
13	LCD Parts Hinge SW FPC	(Fig. D21)	2 Screws (Q)
			2 Locking tabs
			Hinge Arm Cover Top
			Hinge Arm Cover Bottom
			2 Screws (R)
		(Fig. D22)	Hinge Plate
			Connector (A)
			3 Ribs
			LCD Parts
			1 Screw (S)
			1 Locking tab
			Rear Earth Plate B
(Fig. D23)	2 Hinge SW Tapes		
	Hinge SW FPC		
14	LCD Unit	(Fig. D24)	2 Screws (T)
			2 Screws (U)
			6 Locking tabs
		(Fig. D25)	LCD Case (Bottom)
			Connector (B)
			LCD Hinge Unit
			LCD Case (Top)
LCD Unit			

### 8.3.1. Removal of the Rear Case Unit

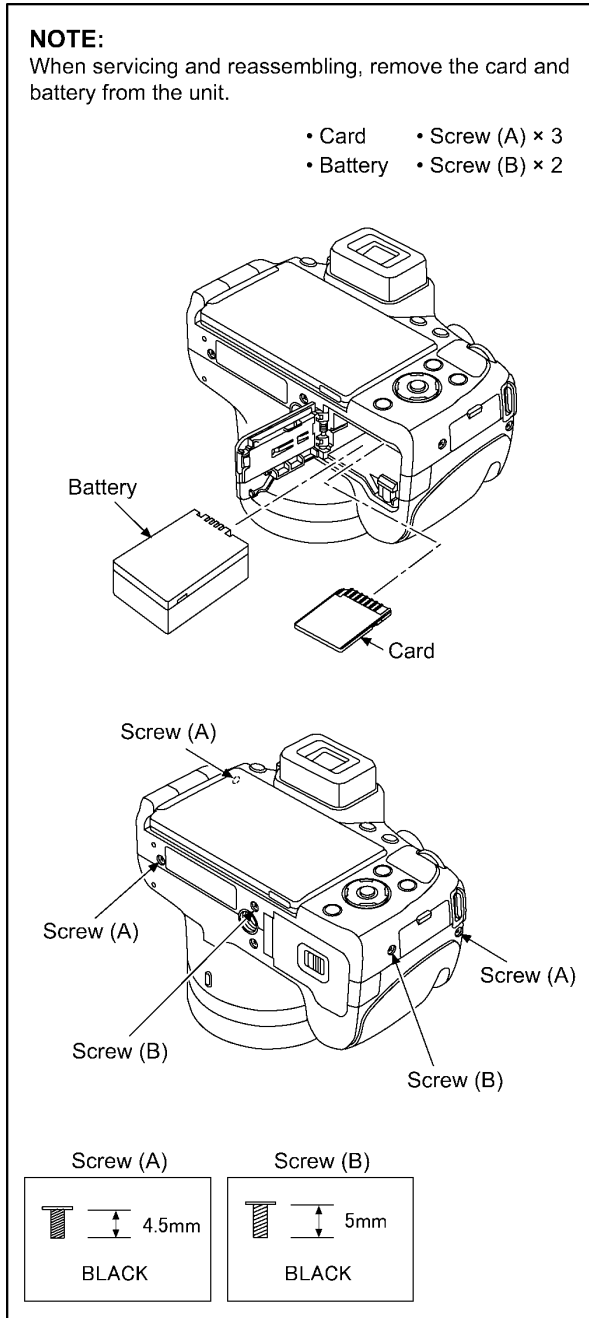

(Fig. D1)

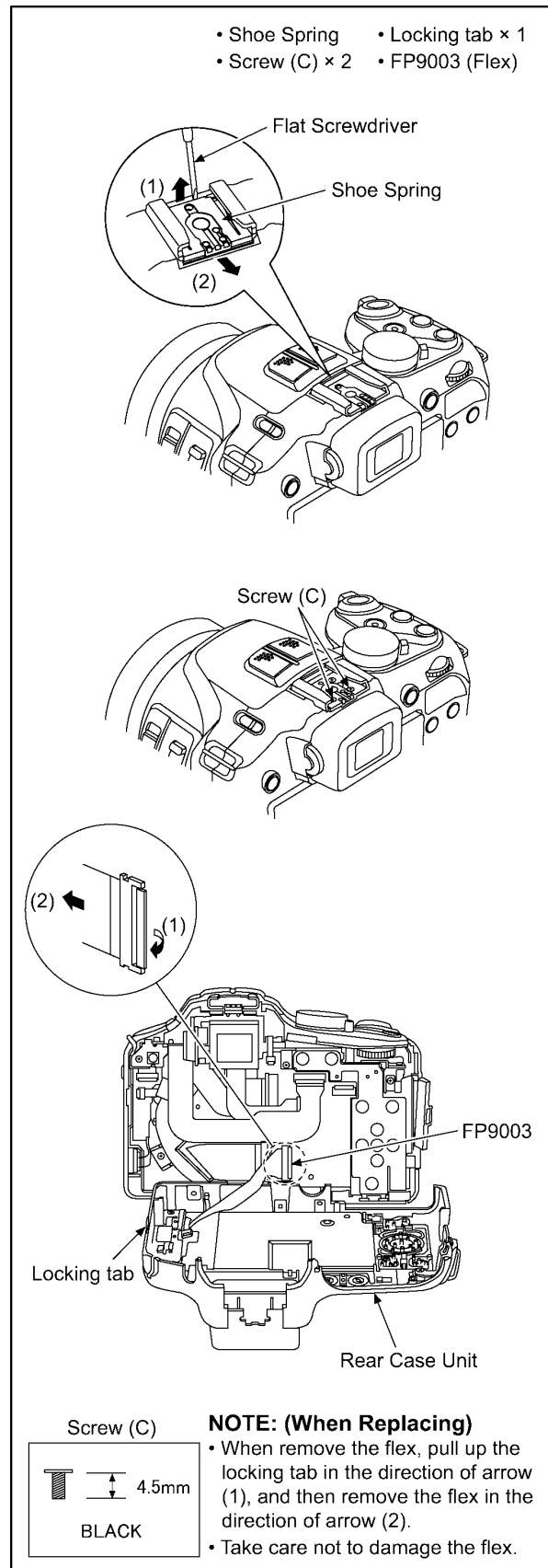

(Fig. D2)



### 8.3.2. Removal of the Rear Operation Unit

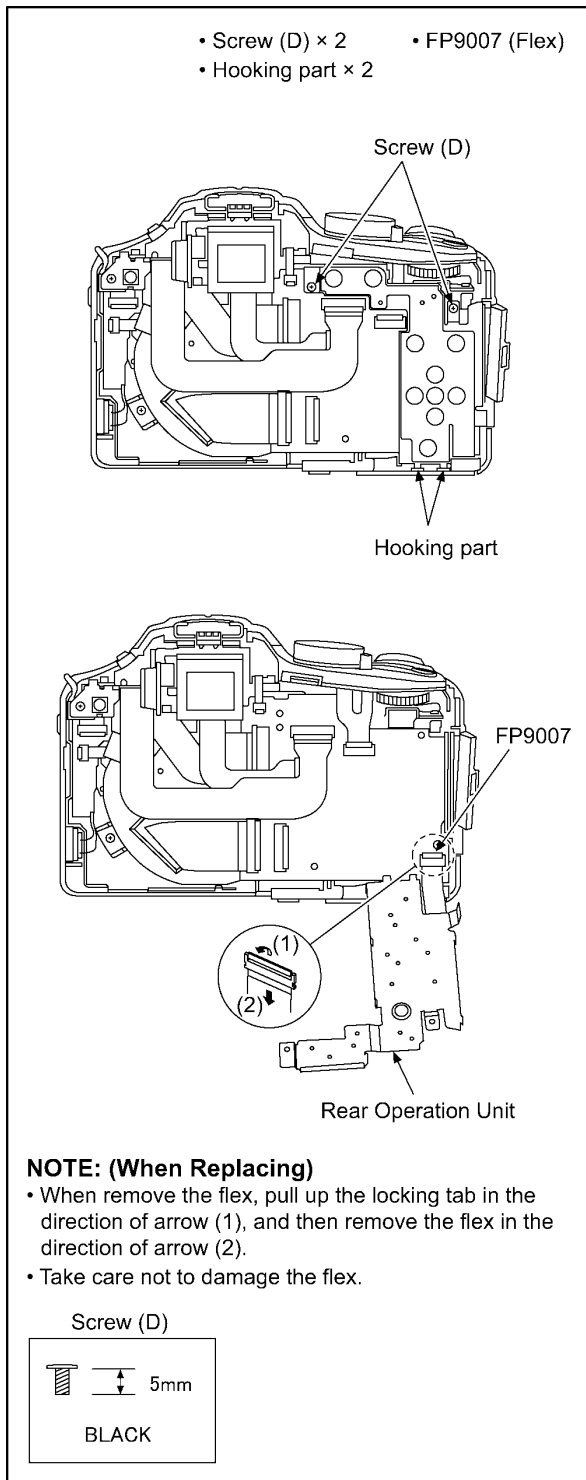

(Fig. D3)

### 8.3.3. Removal of the Main P.C.B.

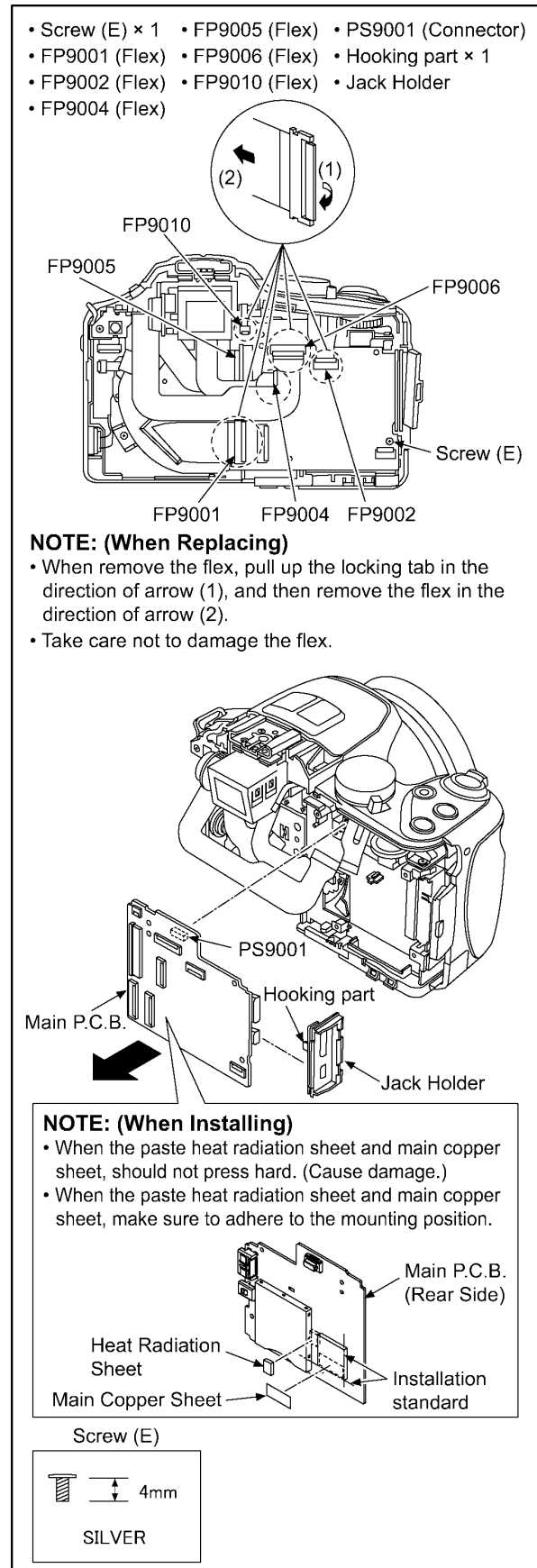

(Fig. D4)

### 8.3.4. Removal of the Top Operation Unit

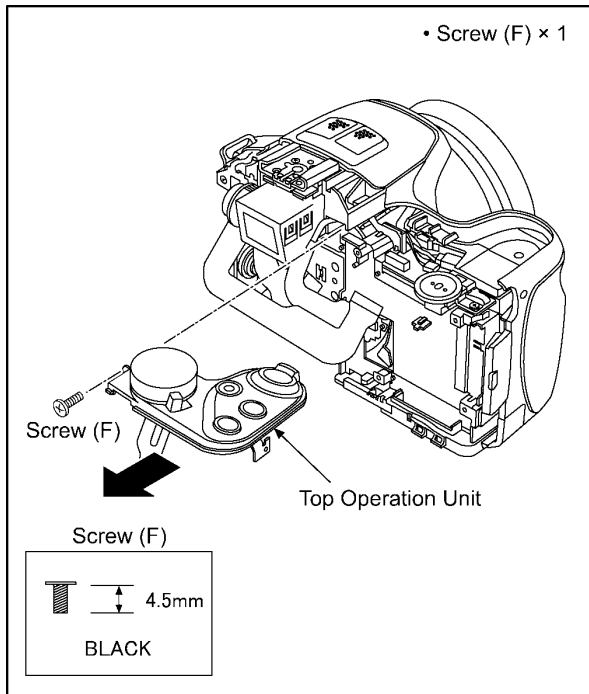

(Fig. D5)

#### IMPORTANT NOTICE:

- Take care not apply any bending load to the E.Capacitor.
- It brings about the possibility of P.C.B. and/or component damage on the Capacitor Unit.

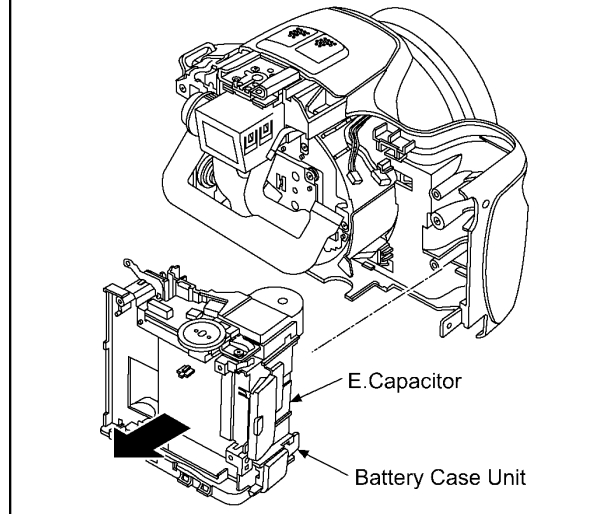

(Fig. D7)

### 8.3.5. Removal of the Battery Case Unit

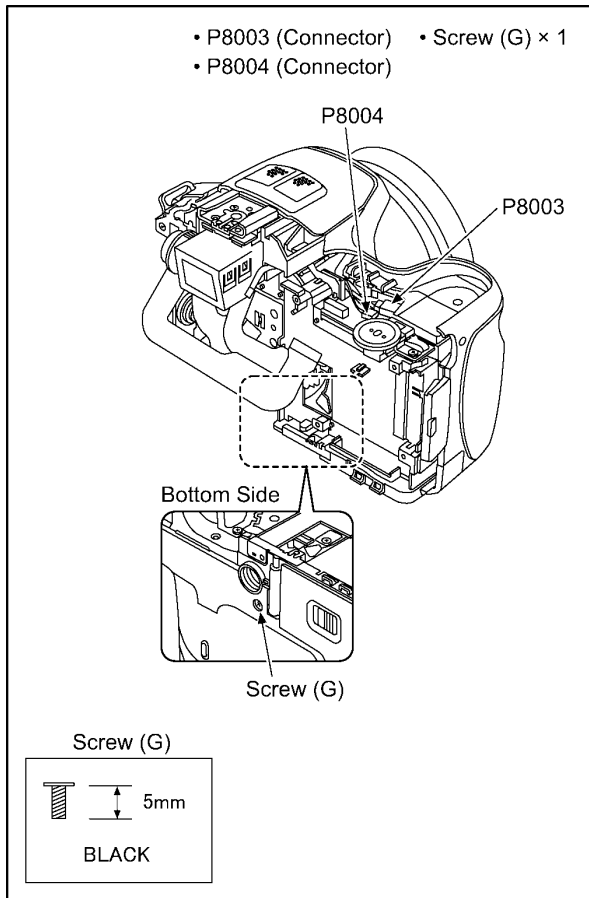

(Fig. D6)

### 8.3.6. Removal of the Lens Unit (W/MOS)

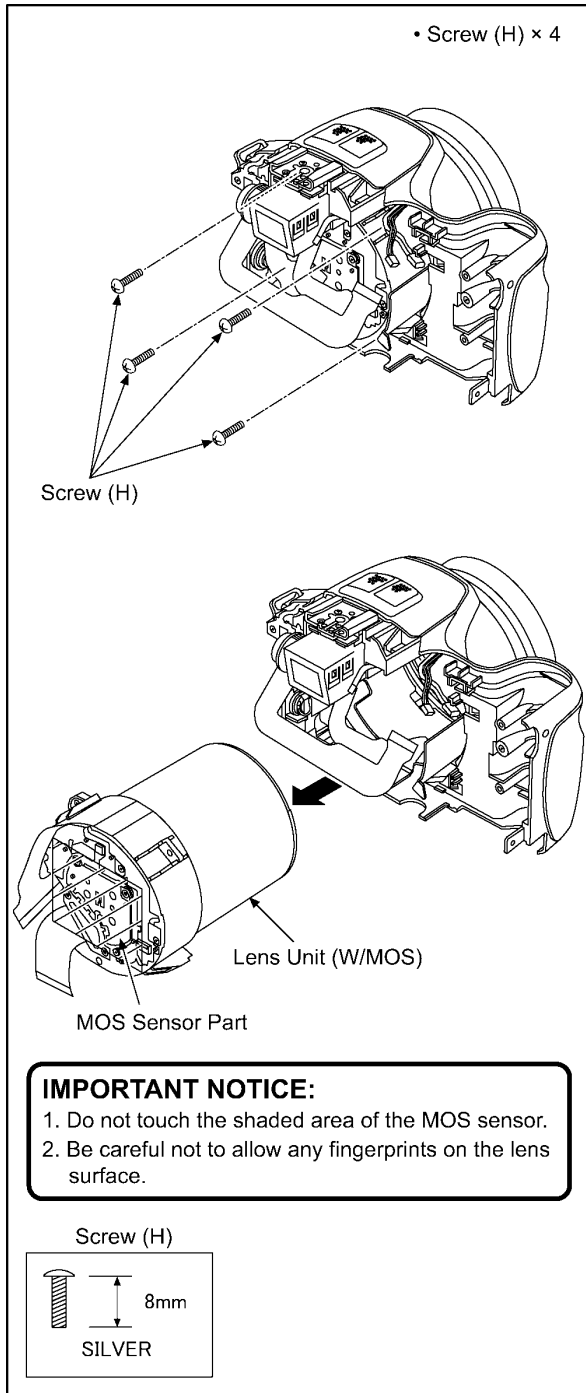

(Fig. D8)

### 8.3.7. Removal of the EVF Unit & Flash Parts

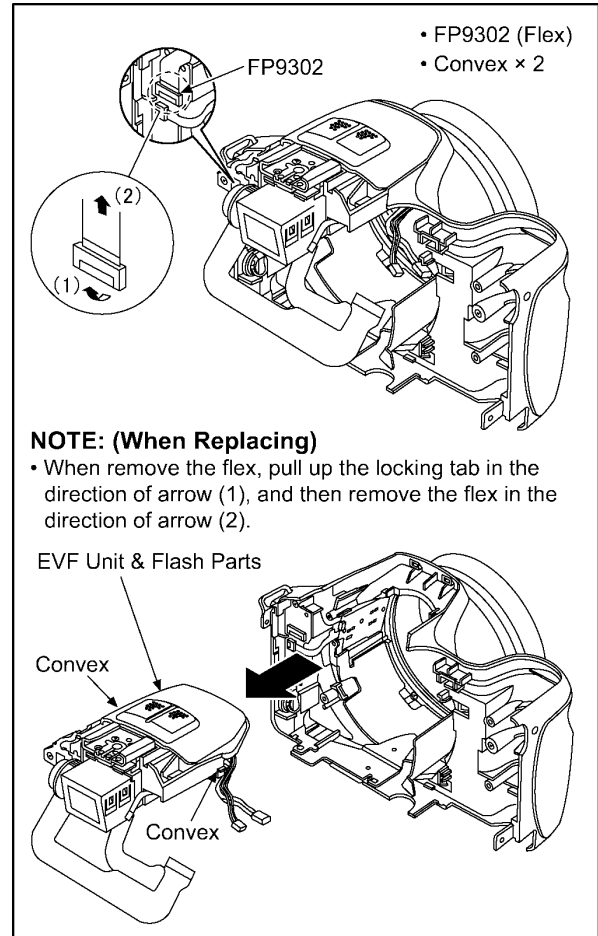

(Fig. D9)

### 8.3.8. Removal of the Sub P.C.B. and Speaker

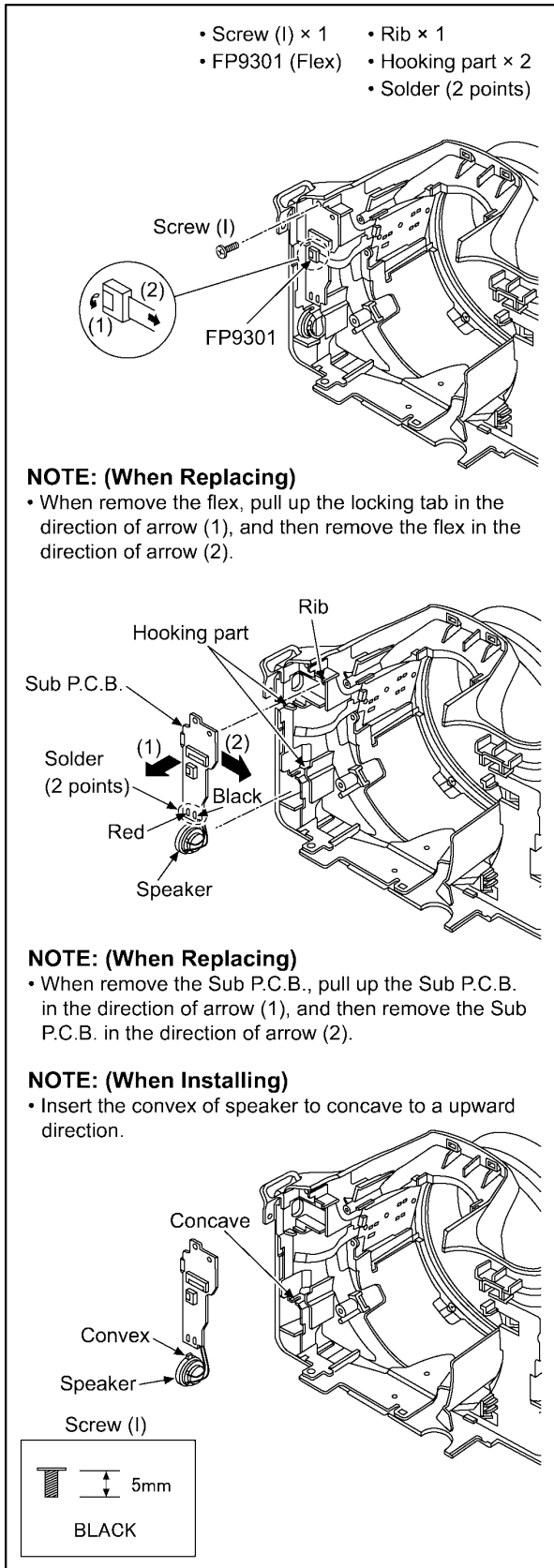

(Fig. D10)

### 8.3.9. Removal of the Side Switch Unit

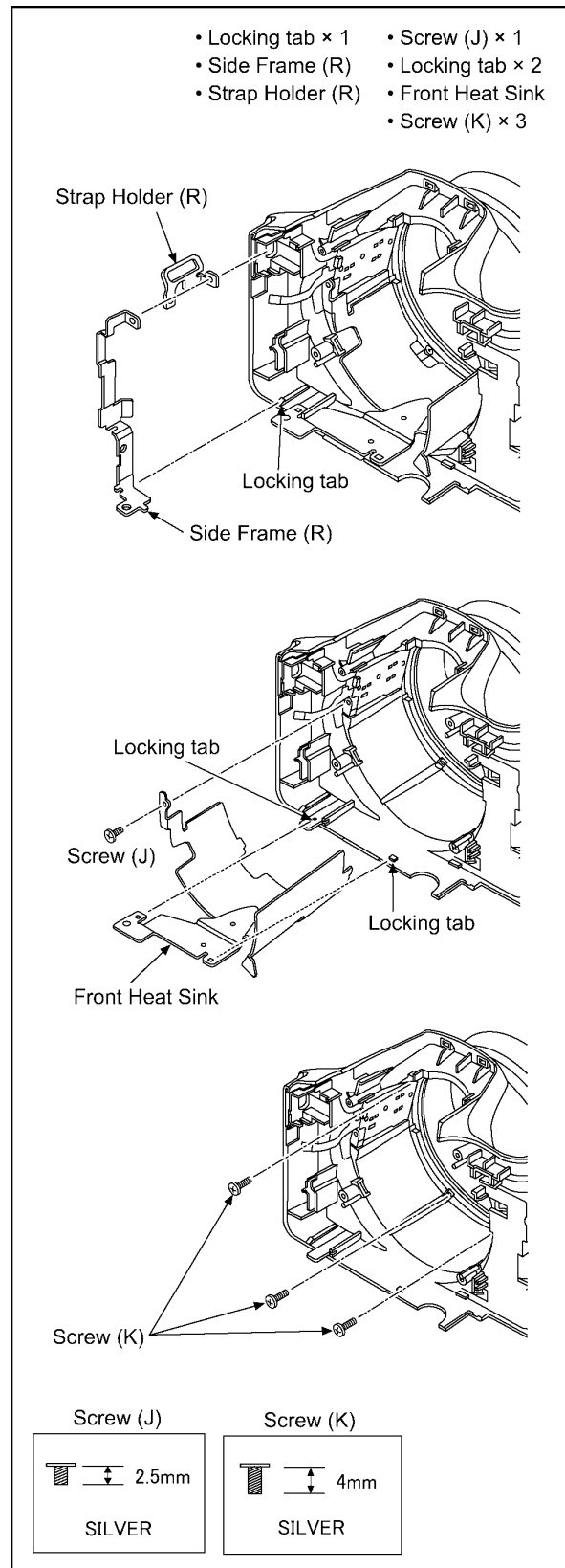

(Fig. D11)

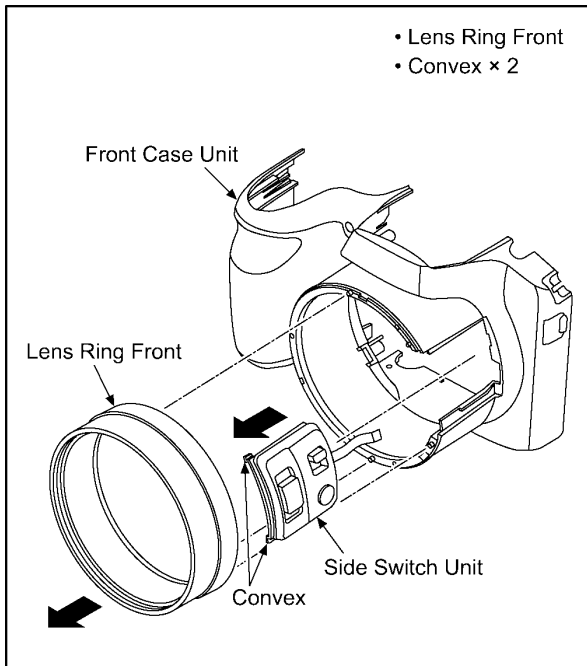

(Fig. D12)

### 8.3.10. Removal of the Flash P.C.B.

#### IMPORTANT NOTICE:

• Take care not apply any bending load to the E.Capacitor.  
It brings about the possibility of P.C.B. and/or component damage on the Capacitor Unit.

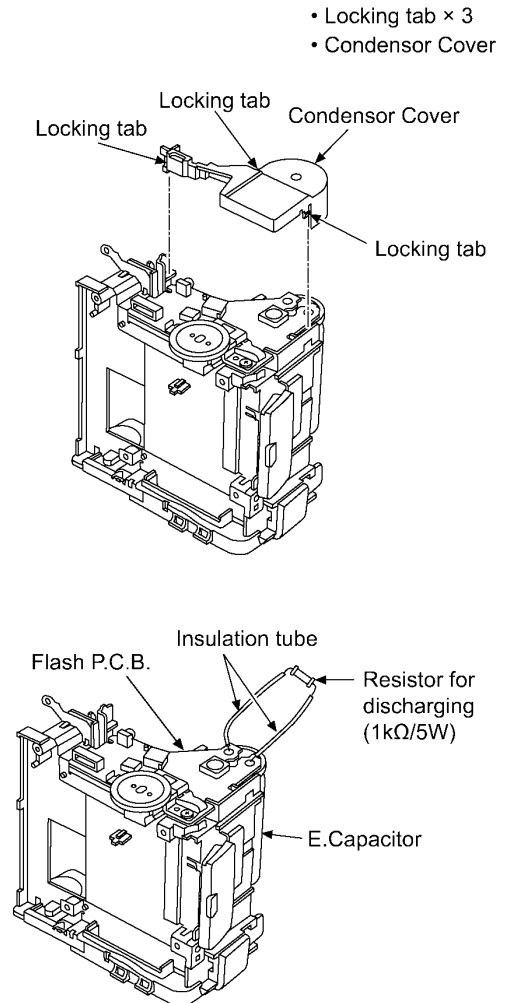

#### ⚠ CAUTION

**Be sure to discharge the E.Capacitor on Capacitor Unit before disassembling.**

1. Remove the Condensor Cover.
2. Put the insulation tube on the lead part of resistor (ERG5SJ102: 1kΩ/5W).
3. Put the resistor between both terminals of E.Capacitor on Capacitor Unit for approx. 5 seconds.

(Fig. D13)

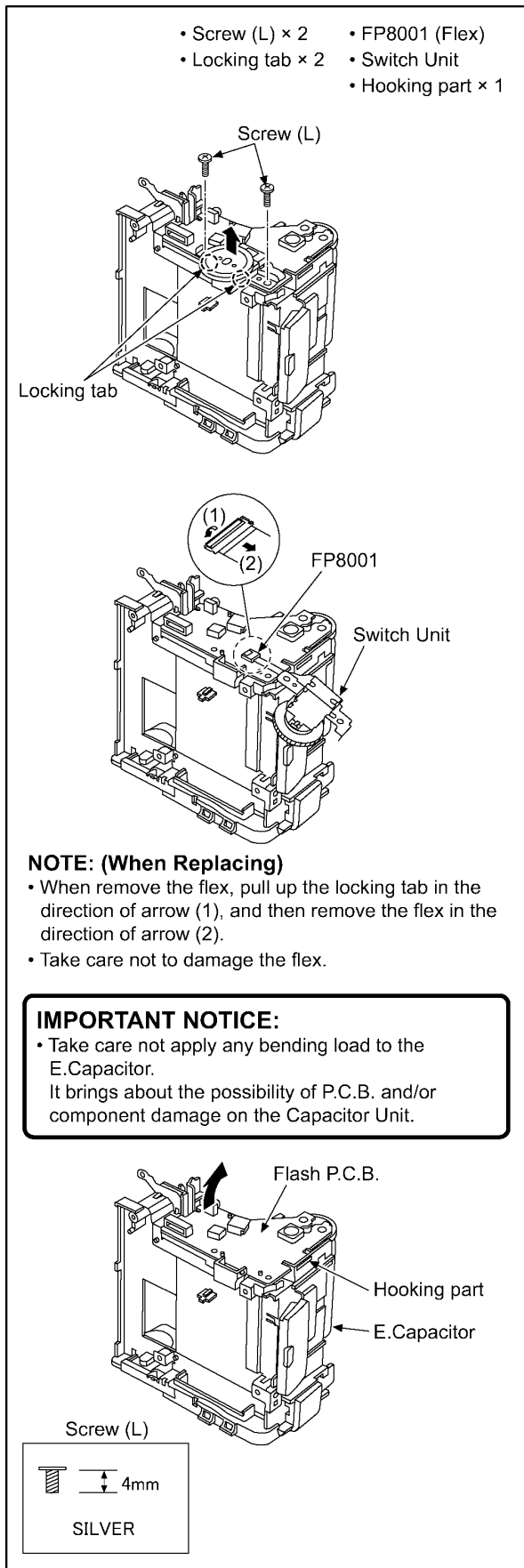

(Fig. D14)

### 8.3.11. Removal of the EVF Unit

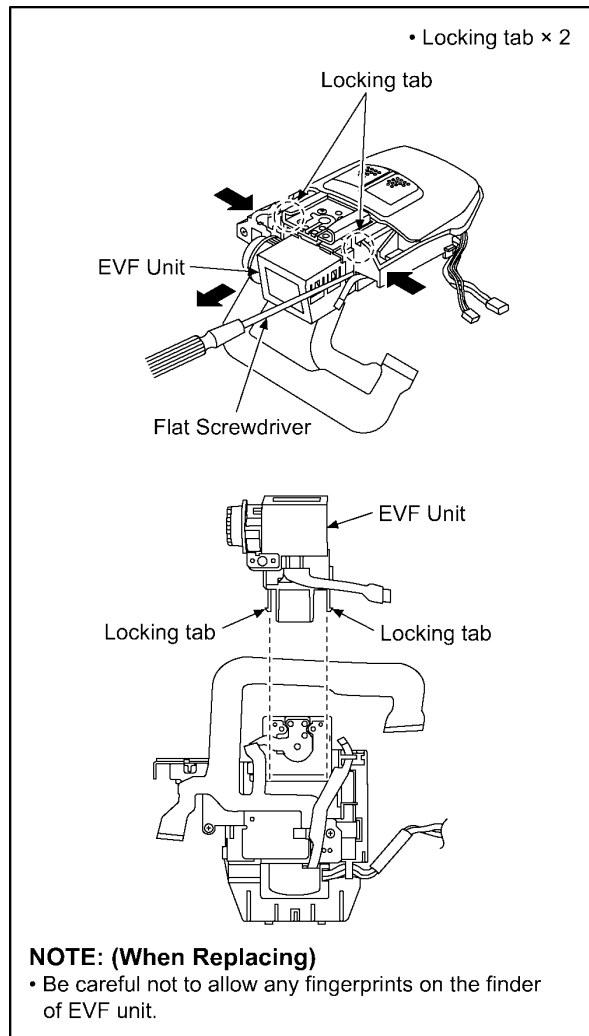

(Fig. D15)

### 8.3.12. Removal of the Hot Shoe Unit, Flash and Mic FPC Unit

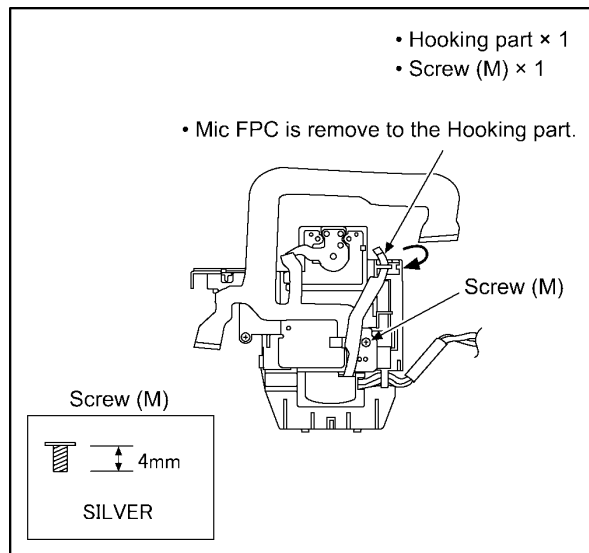

(Fig. D16)

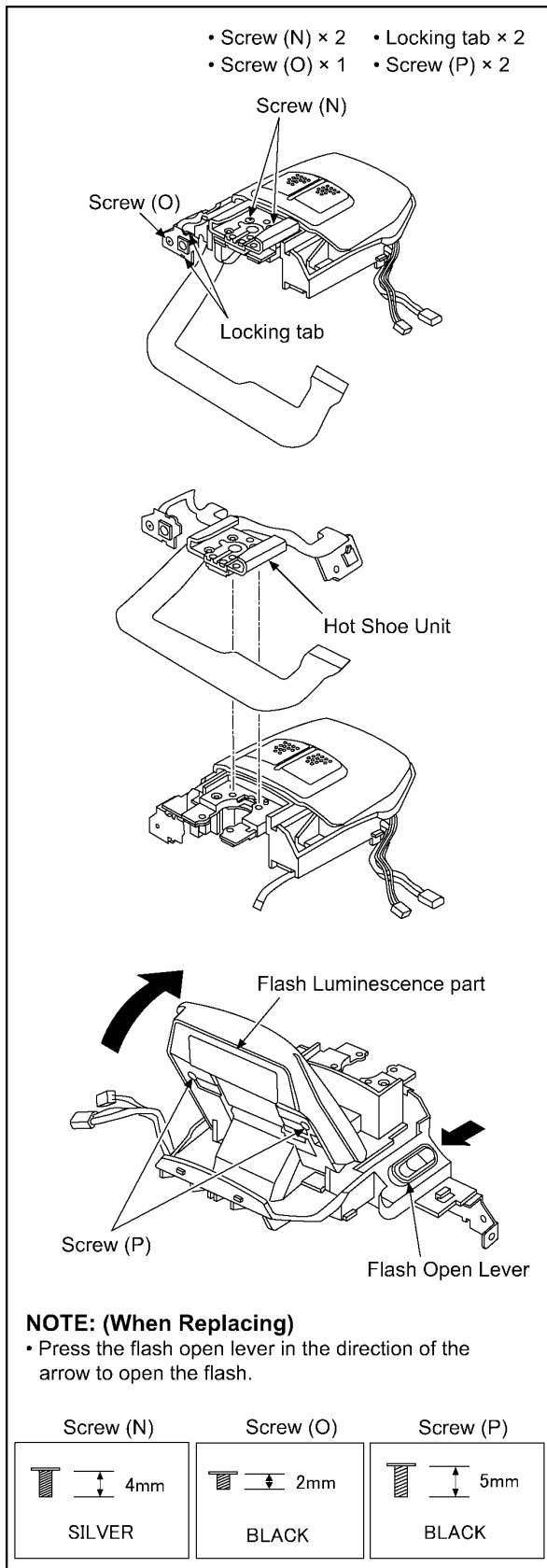

(Fig. D17)

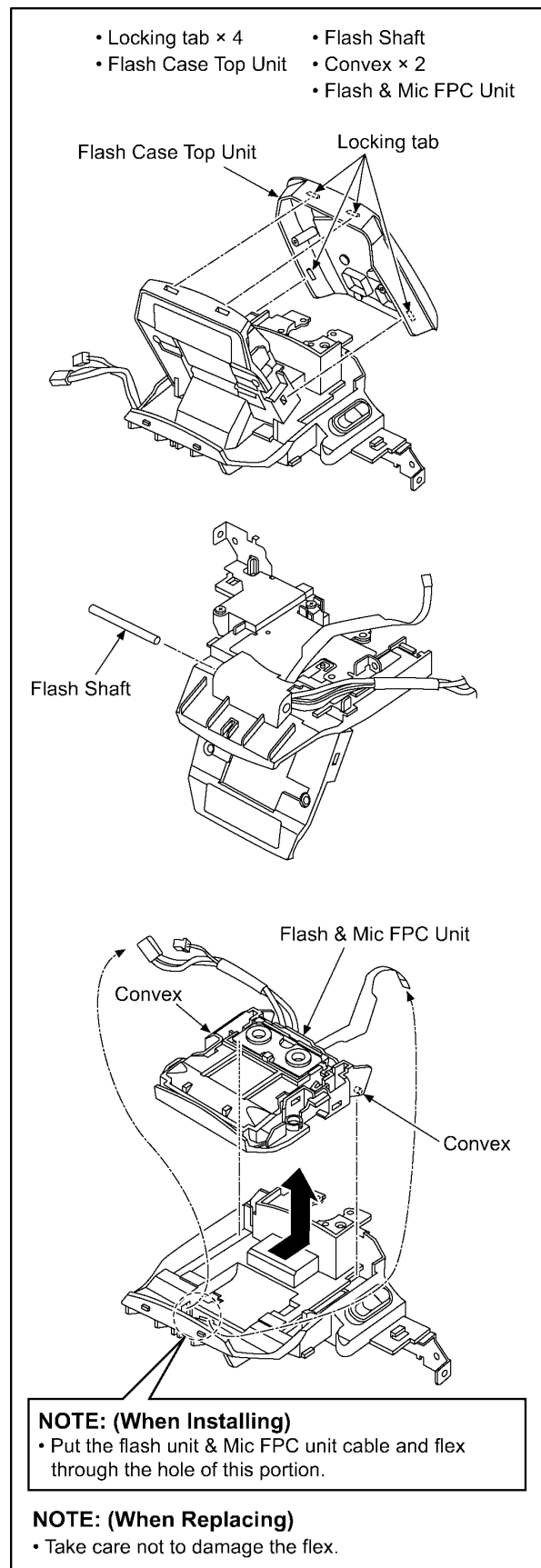

(Fig. D18)

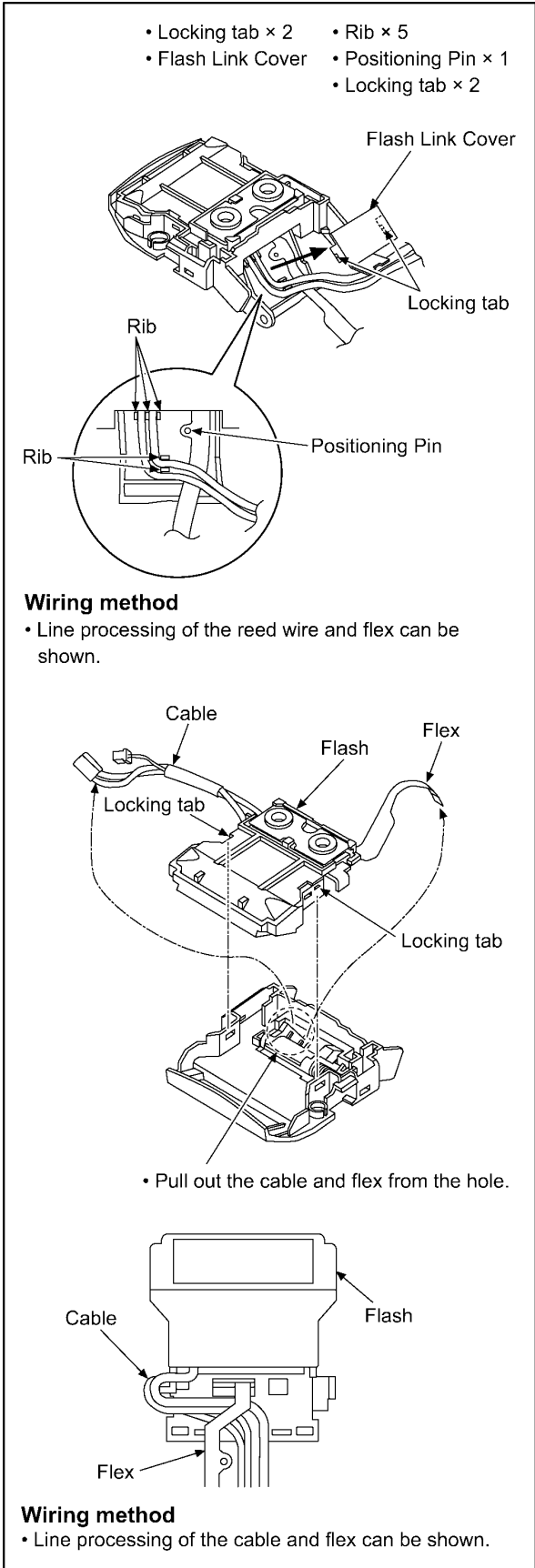

(Fig. D19)

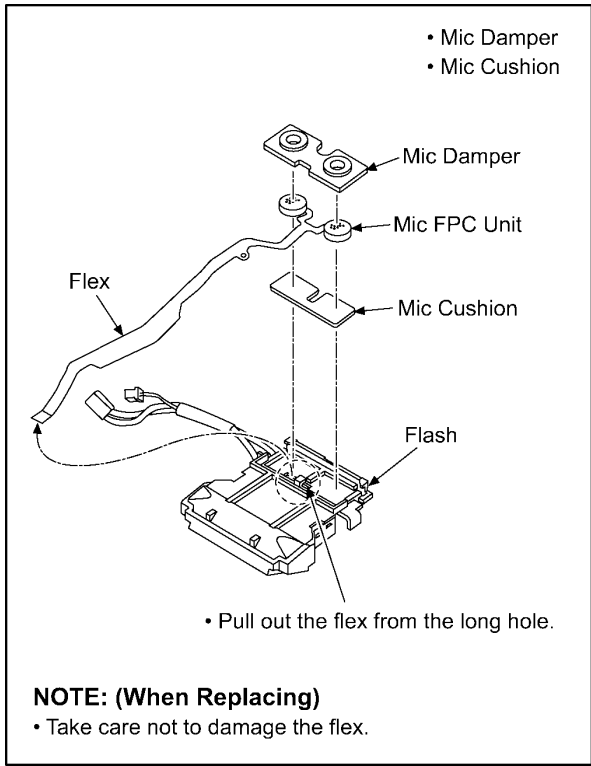

(Fig. D20)



### 8.3.13. Removal of the LCD Parts and Hinge SW FPC

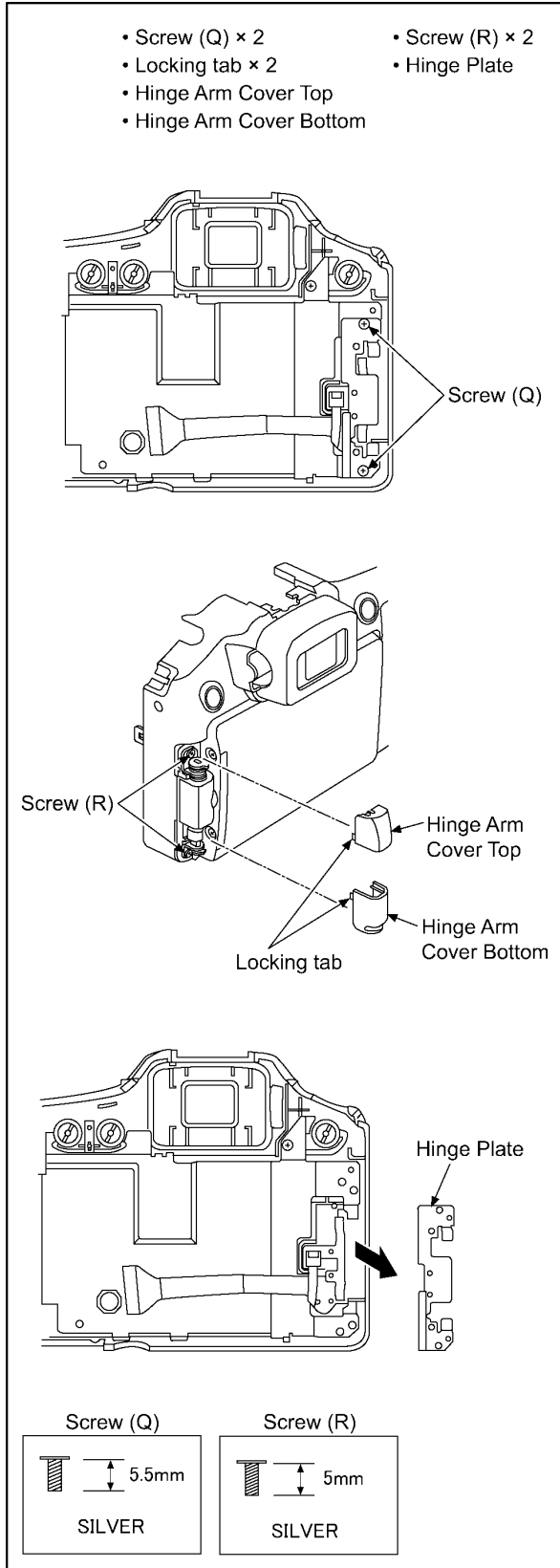

(Fig. D21)

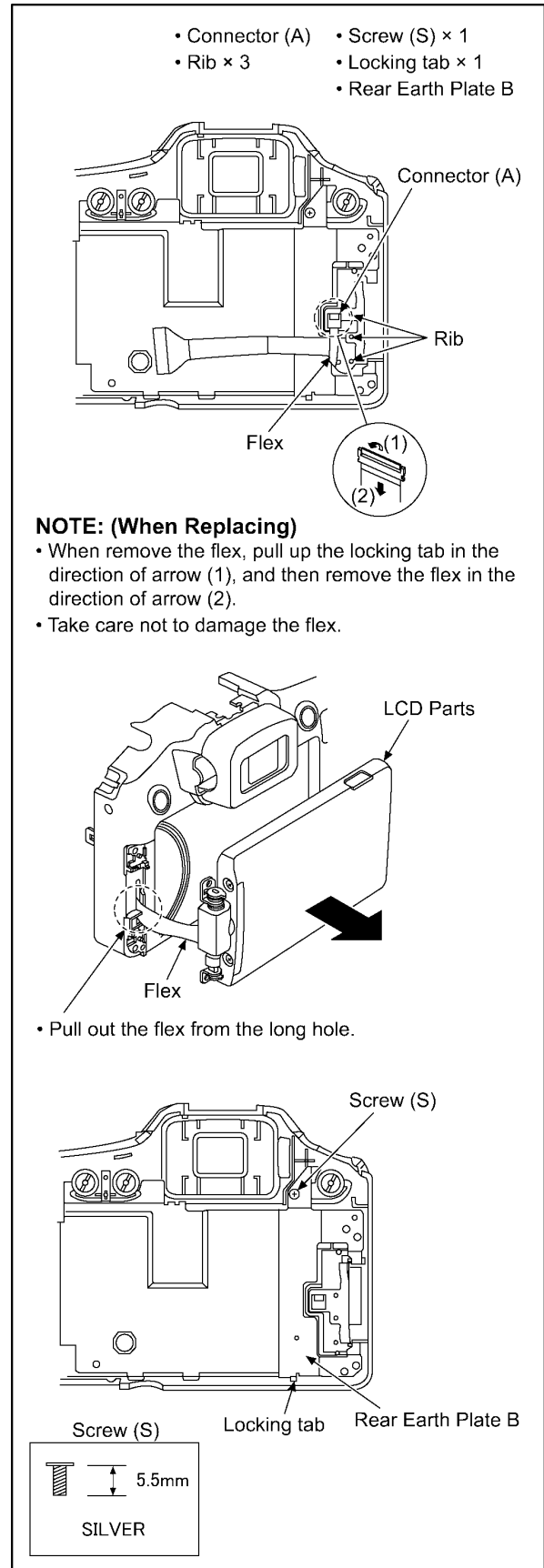

(Fig. D22)

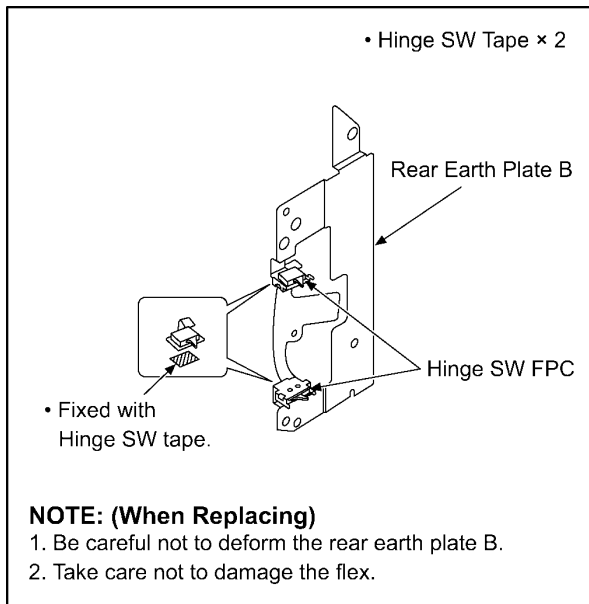

(Fig. D23)

### 8.3.14. Removal of the LCD Unit

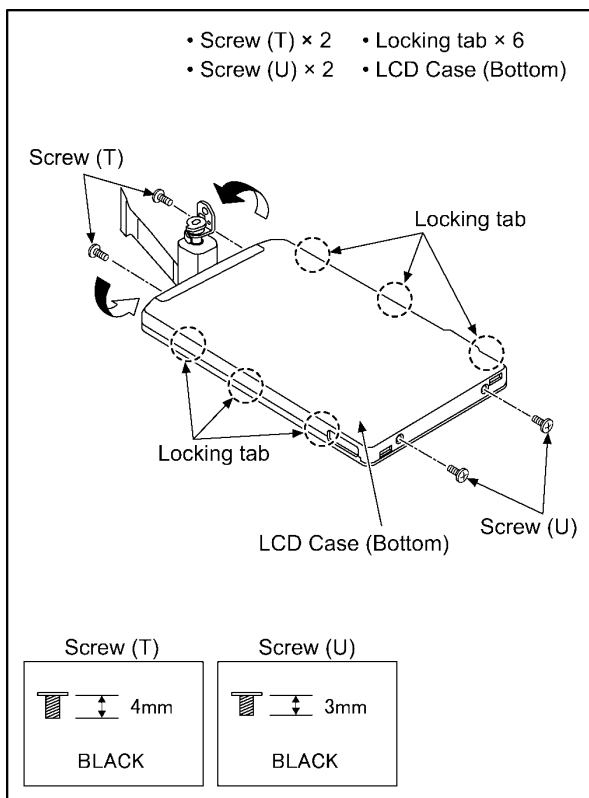

(Fig. D24)

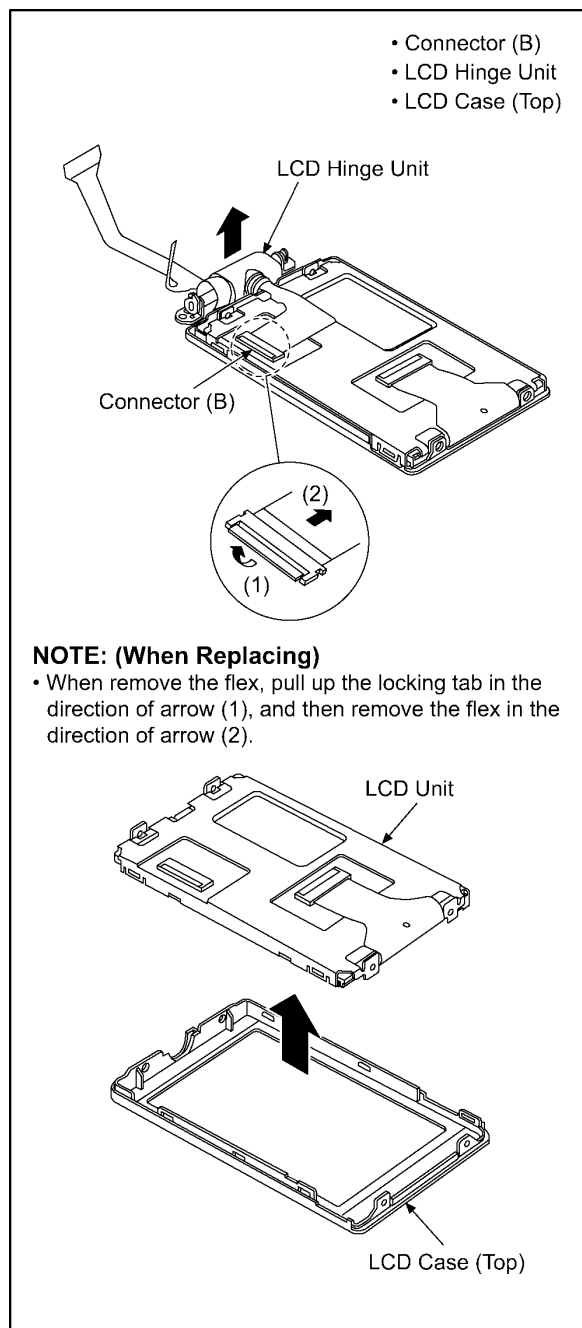

(Fig. D25)

**NOTE: (When Installing)**

- Make sure to confirm the following points when installing:
- The screw is tightened enough.
  - Installing conditions are fine. (No distortion, no abnormal space.)
  - No dust and/or dirt on Lens surfaces.
  - LCD image is fine. (No dust and dirt on it, and no gradient images.)

## 8.4. Lens Disassembly Procedure

### Precaution:

1. Do not remove the MOS unit when disassembling or re-assembling the lens in order to maintain it clean.  
The screws for fixing the MOS unit to the master flange unit are locked by glue with the adjustment of the installation angle of the MOS unit to the lens (optical axis adjustment) finished.  
When remove it, refer to item "8.5."
2. Keep dust or dirt away from the lens.  
To remove dirt or dust from the lens, blow with dry air.
3. Do not touch the lens surface.
4. Use lens cleaning KIT (VFK1900BK).
5. Apply grease as shown on item "8.4.8." and "8.4.9." in the figure.

### 8.4.1. Removal of the Lens Flex Unit

1. Unscrew the 2 screws (A).
2. Remove the 10 Ribs.

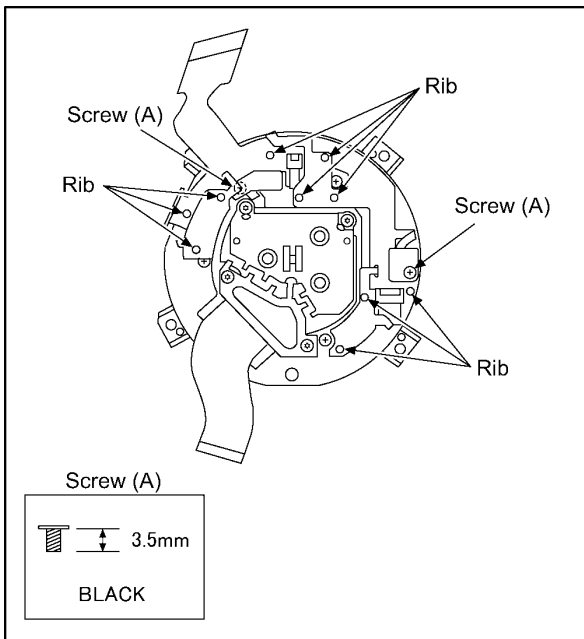

3. Remove the 3 connector.
4. Remove the lens flex unit.

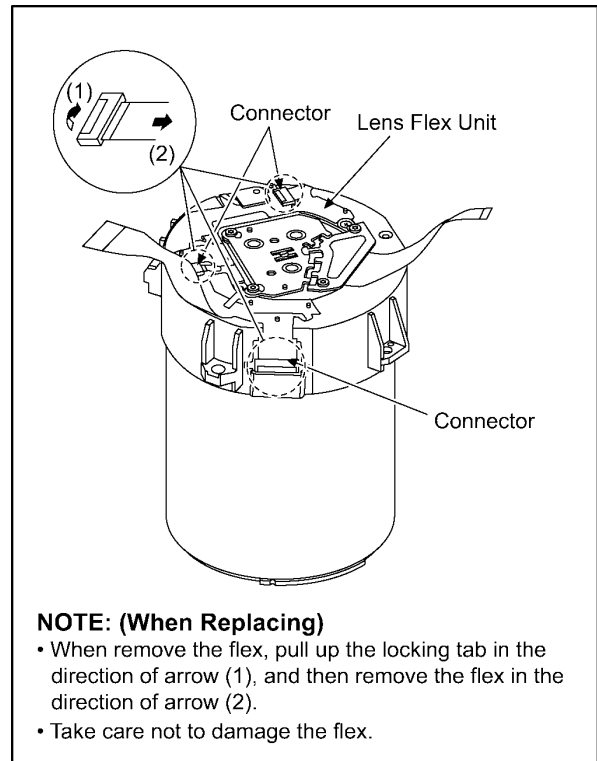

### 8.4.2. Removal of the Master Flange Unit

1. Unscrew the 3 screws (B).
2. Remove the master flange unit.

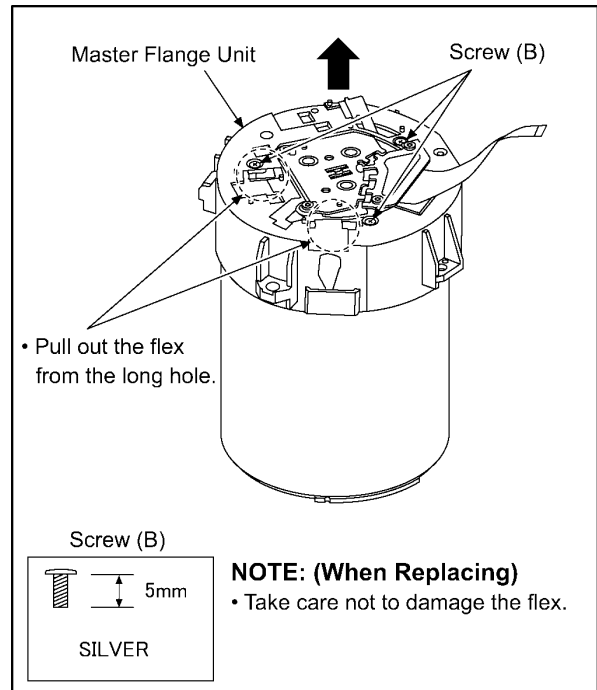

### How to Install

1. Put in the master flange unit to the middle frame unit and cam frame.
2. Pull out the flex from the long hole.
3. Fasten the 3 screws (B).
4. Turn the cam frame in the direction of arrow, and push the master flange unit.

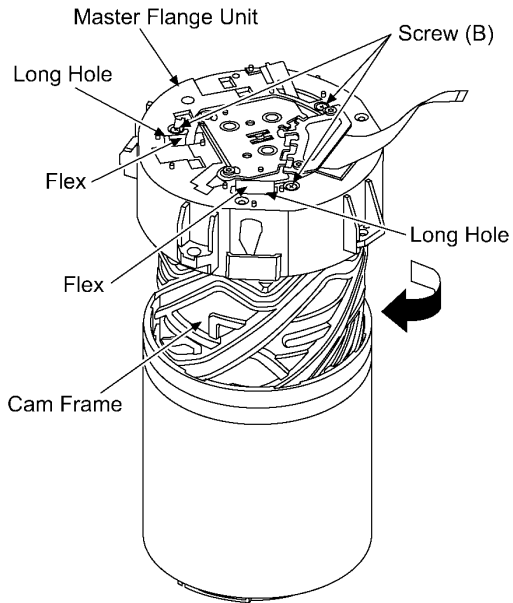

### NOTE: (When Installing)

- Take care not to damage the flex.

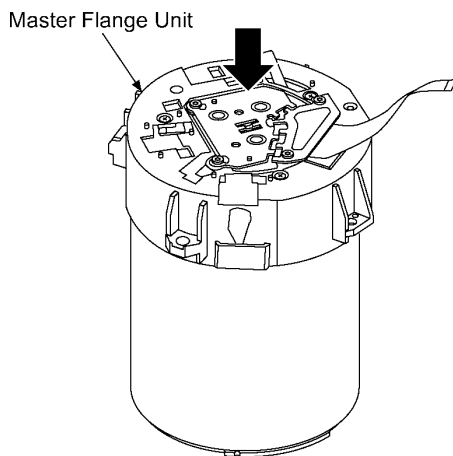

### 8.4.3. Removal of the Zoom Motor

1. Unscrew the 2 screws (C).

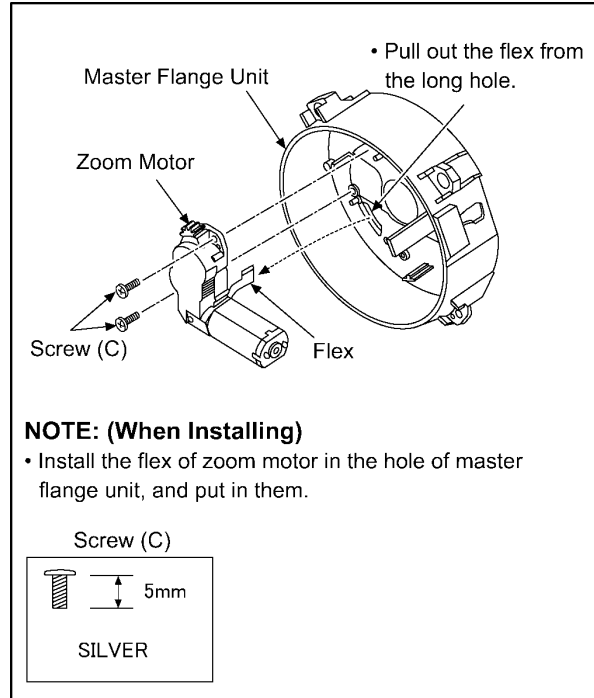

#### 8.4.4. Removal of the 1st Lens Frame Unit

1. Turn the cam frame in the direction of arrow fully, and remove the 1st lens frame unit.

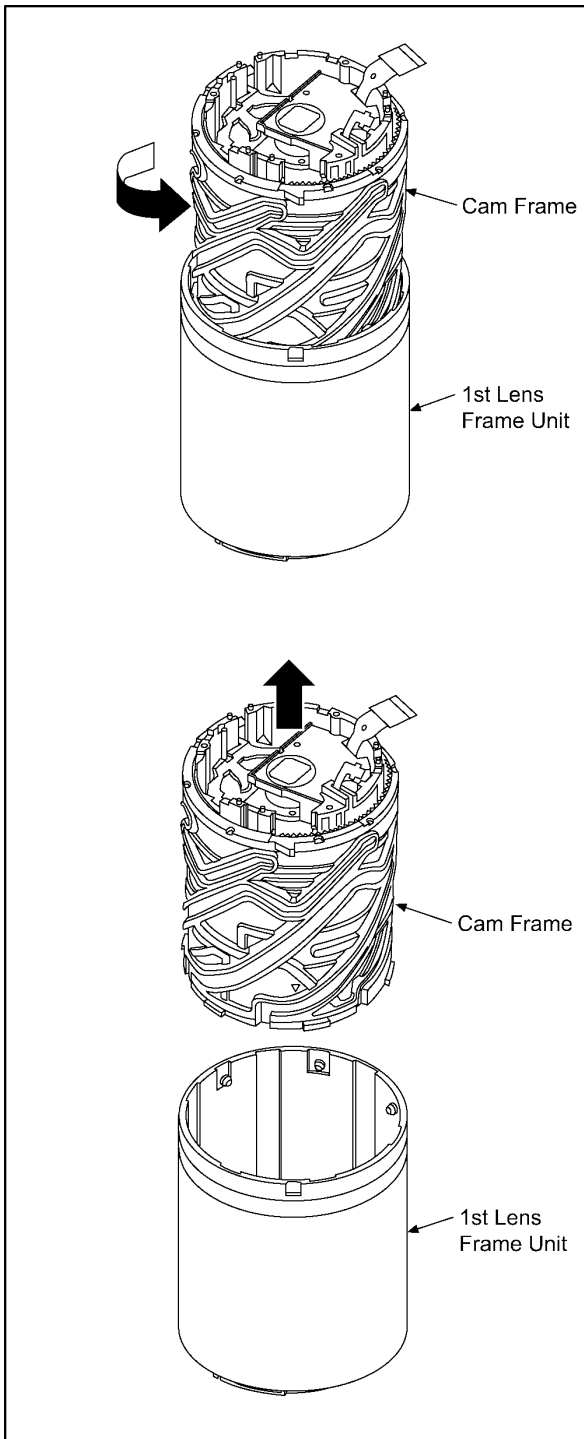

#### How to Install

1. Align the groove of cam frame and the groove of middle frame unit.

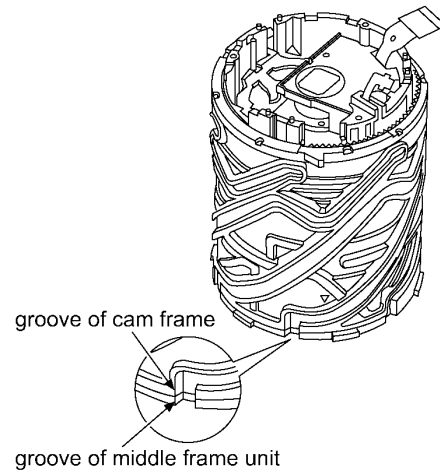

2. Align the  $\Delta$  mark of cam frame and concave of 1st lens frame unit, and then install them.

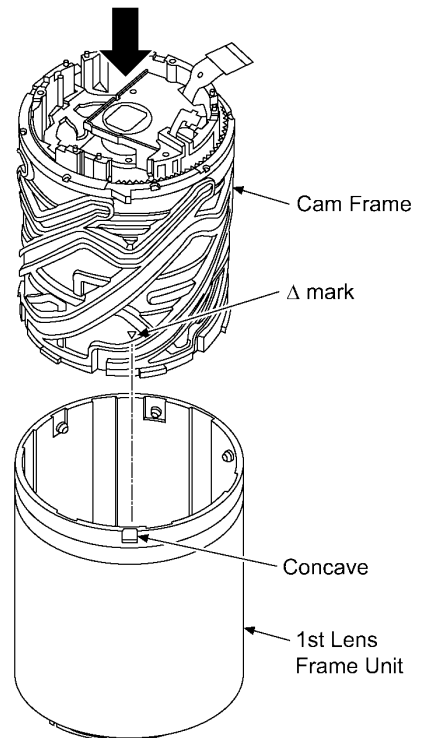

#### NOTE: (When Installing)

- Take care not to put fingerprint of the lens.

3. Install the cam frame. And turn the cam frame in the direction of arrow a little.

Rotation angle: 2 gear  $\pm$  1 gear

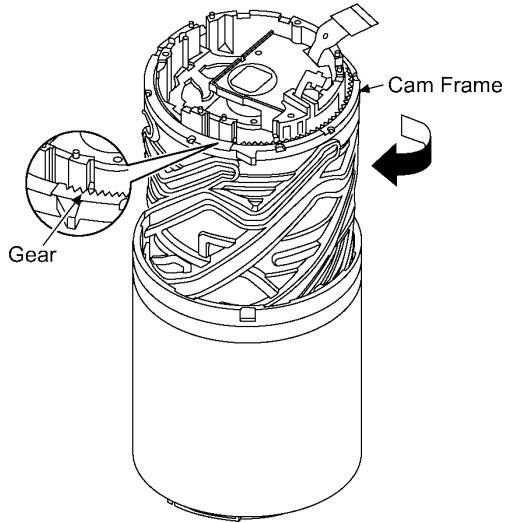

4. Insert the flex to slit of middle frame unit.

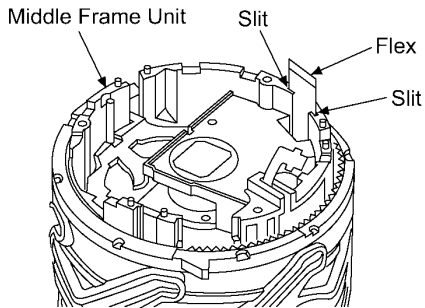

**NOTE: (When Replacing)**

- Take care not to damage the flex.
- Take care not to put fingerprint of the lens.

### 8.4.5. Removal of the 5th Lens Frame Unit

1. Remove the 5th lens frame unit in the direction of arrow.

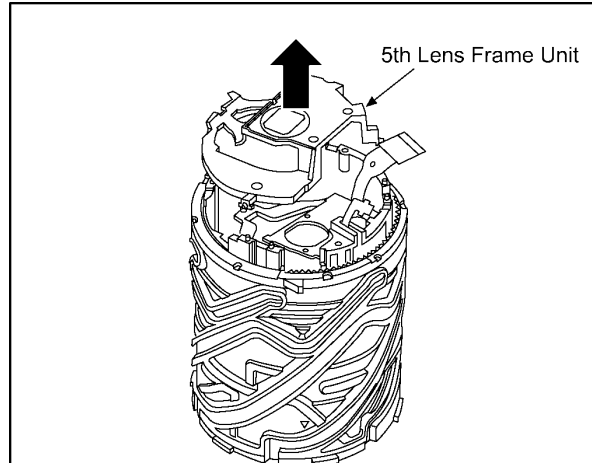

**NOTE: (When Replacing)**

- Take care not to put fingerprint of the lens.

**How to Install**

1. Align the convex of 5th lens frame unit and groove of middle frame unit, and then install them.

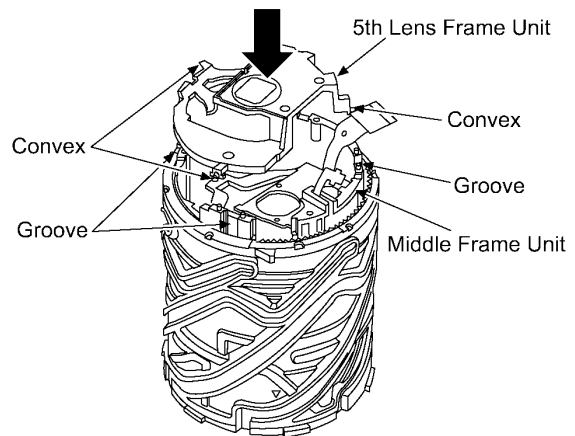

**NOTE: (When Installing)**

- Take care not to put fingerprint of the lens.

### 8.4.6. Removal of the 2nd Lens Frame Unit

1. Hold the middle frame unit, and turn the cam frame unit in the direction of arrow (1) fully.(about half turn)
2. Reverse the cam frame, and remove the 2nd lens frame unit. (Catch the 2nd lens frame unit.)

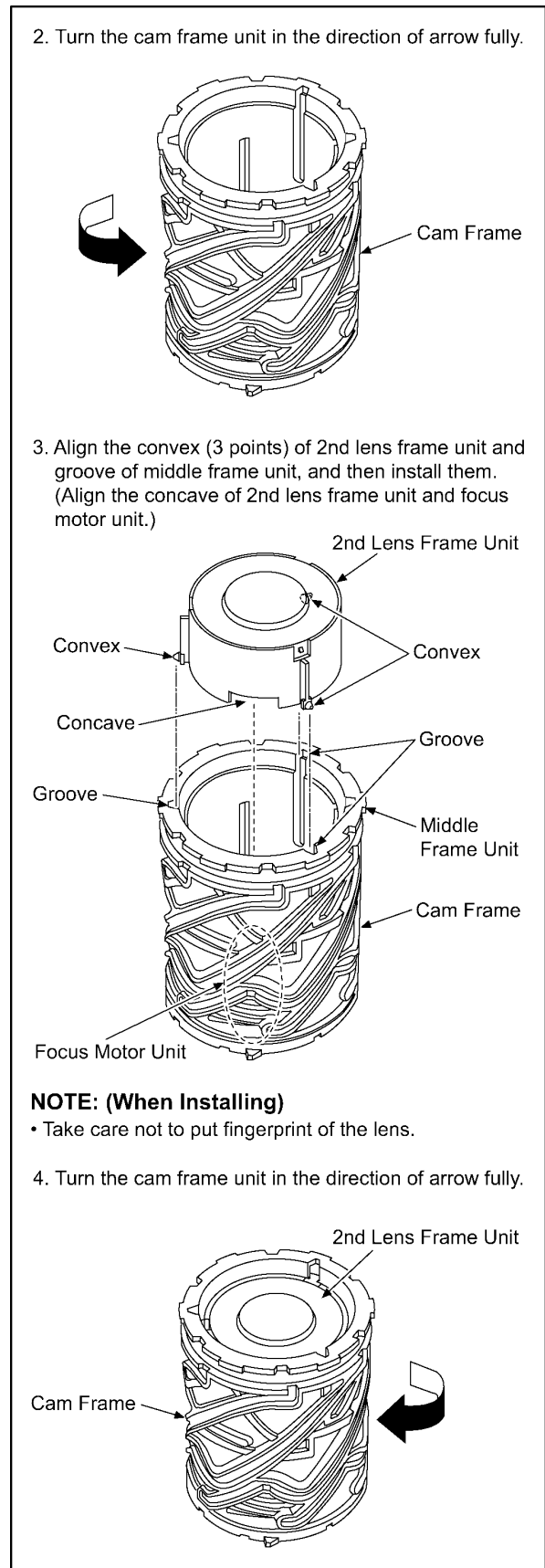
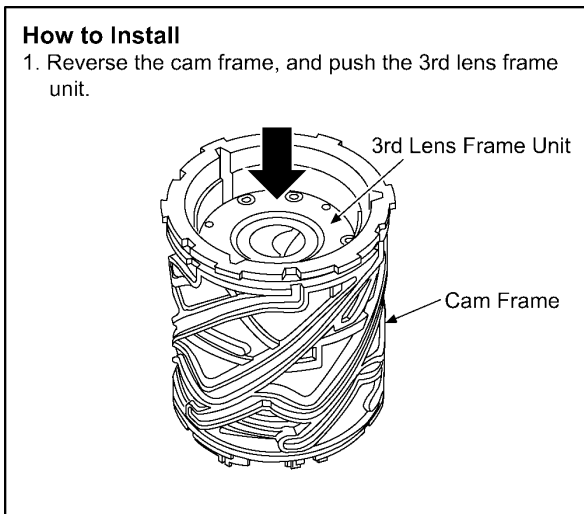
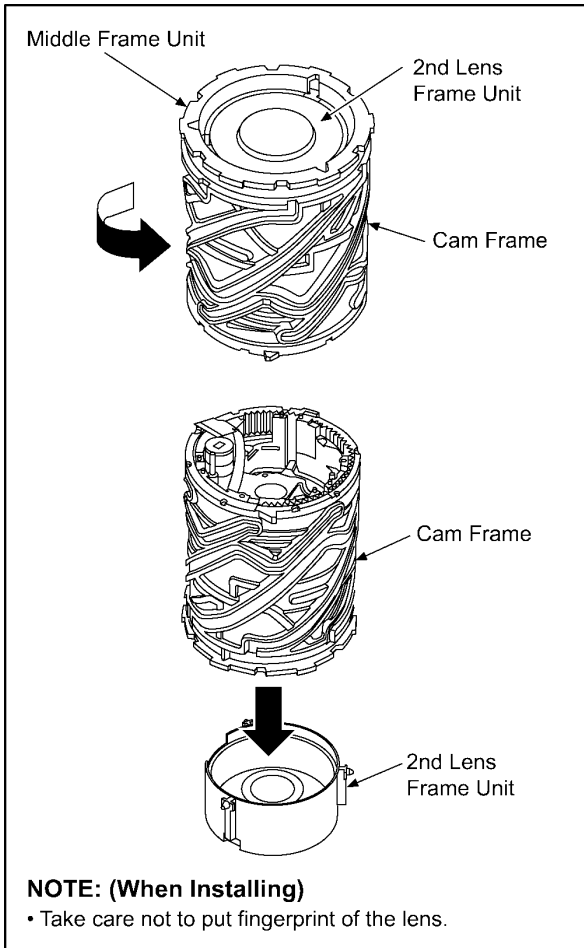

### 8.4.7. Removal of the Cam Frame Unit

1. Turn the cam frame unit in the direction of arrow (1) fully.(about half turn)
2. Move the 3rd lens frame unit to bottom. And turn the cam frame unit in the direction of arrow (2) fully, and remove the cam frame unit.

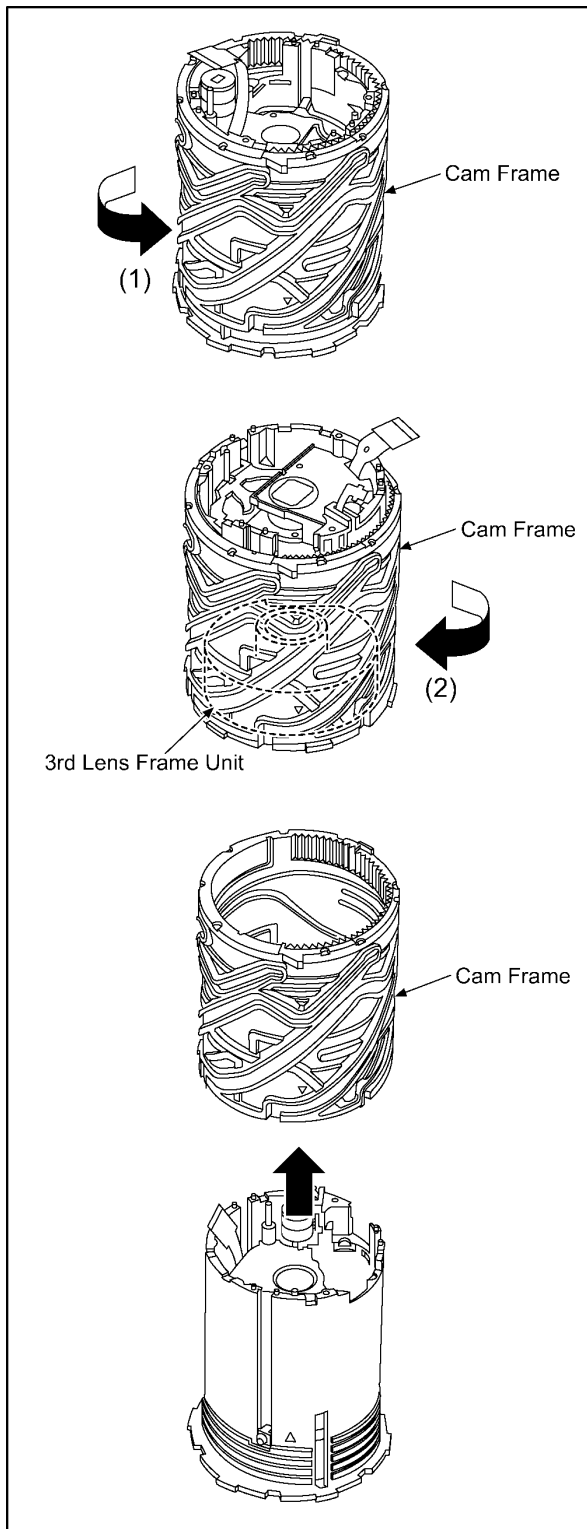

### How to Install

1. Align the  $\Delta$  mark of middle frame unit and  $\Delta$  mark of cam frame, and then install them.

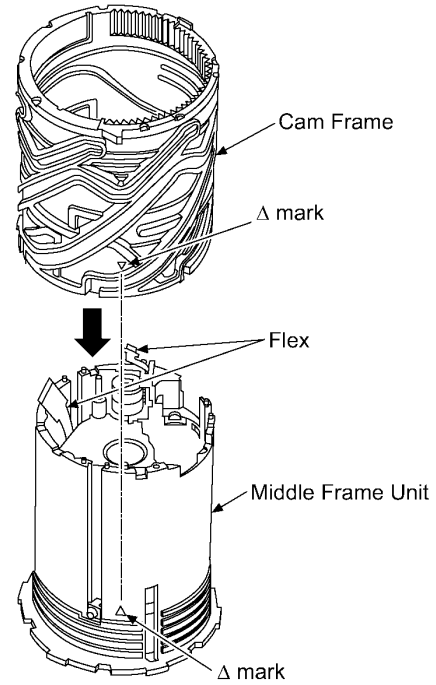

### NOTE: (When Replacing)

- Take care not to damage the flex.
2. Turn the cam frame in the direction of arrow fully.

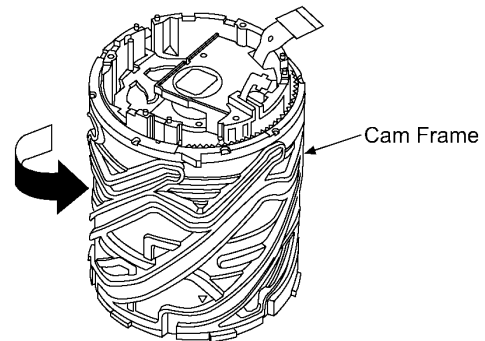



### 8.4.8. Removal of the Focus Motor Unit

1. Unscrew the 2 screws (D).
2. Remove the focus motor unit.  
(Also remove the flex from groove.)

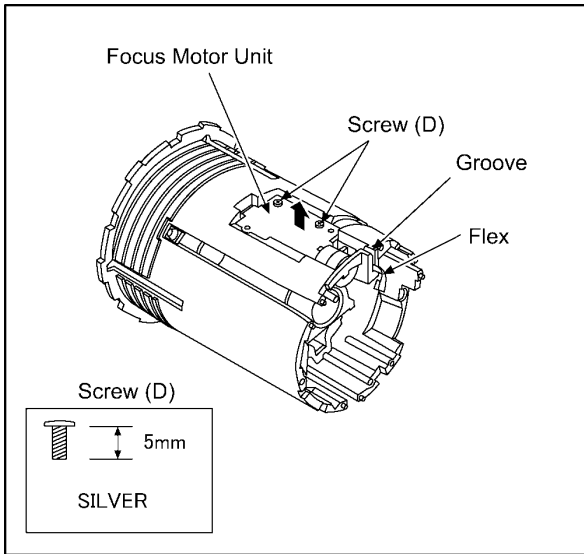

#### How to Install

1. Blow air to the screw shaft of focus motor unit to prevent the adhesion of foreign material.
2. Apply grease to the screw shaft of focus motor unit.

- Grease Application Area  
Grease: VZG0386  
Amount of application:  $4.5 \pm 0.3\text{mg}$

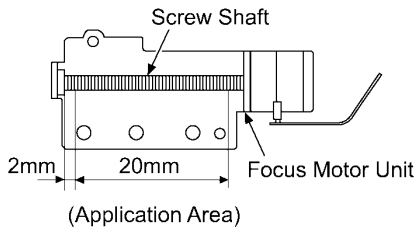

3. Movement the 4th lens frame unit to reference position.

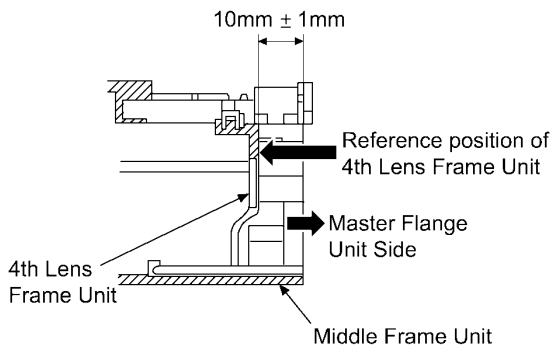

4. Align the screw shaft and rack of 4st lens frame unit.

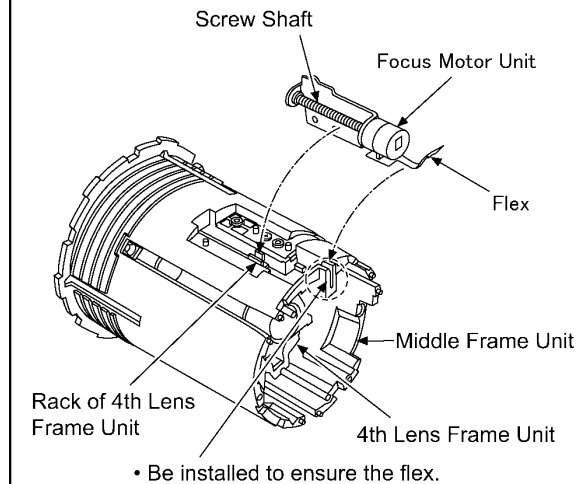

### 8.4.9. Removal of the 4th and 3rd Lens Frame Unit.

1. Remove the 4th lens frame unit and 3rd lens frame unit from middle frame unit.

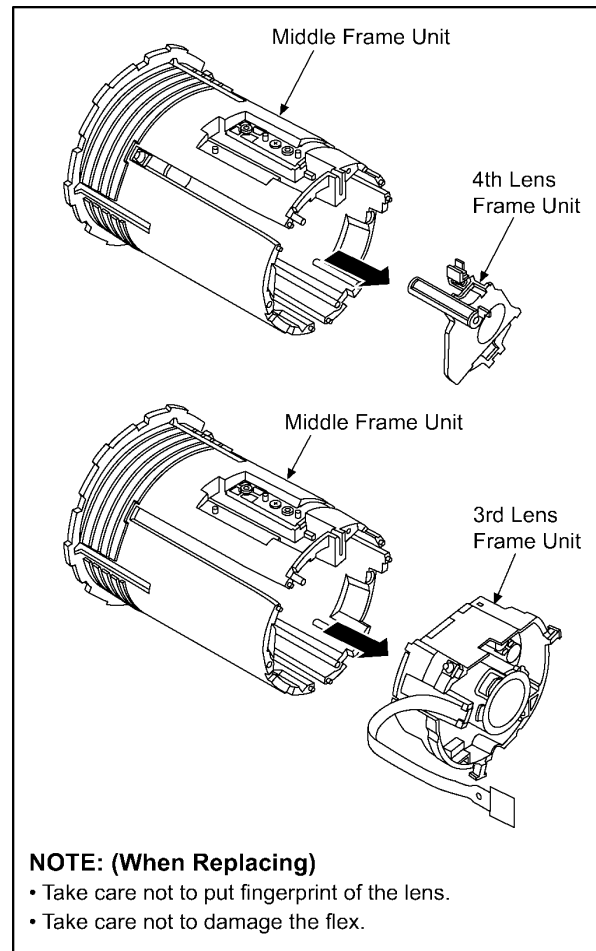

### How to Install

1. Align the convex of 3rd lens frame unit and groove of middle frame unit, and then install them.

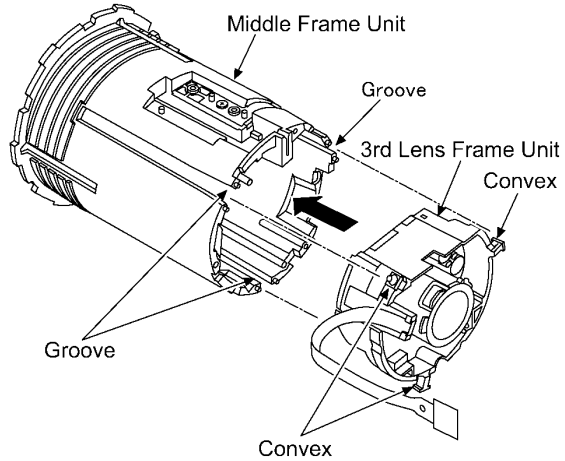

2. Align the hole and groove of 4th lens frame unit and shaft of middle frame unit, and then install them.

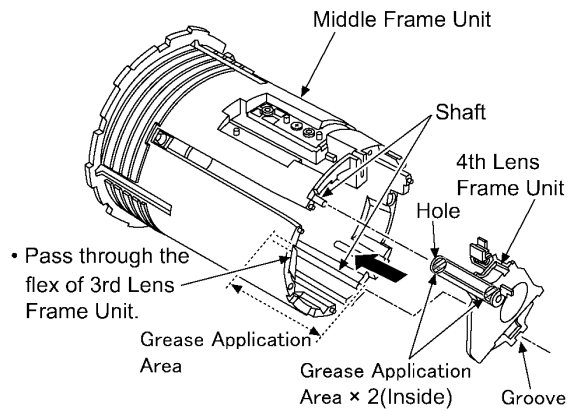

### NOTE: (When Installing)

- Take care not to put fingerprint of the lens.
- Take care not to damage the flex.

#### ■ Grease Application Area

- Hole of 4th lens frame unit (Inside)  
Grease: VZG0386  
Amount of application:  $10 \pm 1\text{mg} \times 2$
- Shaft  
Grease: VZG0386  
Amount of application:  $1.5 \pm 0.1\text{mg}$

## 8.5. Removal of the MOS Unit

When remove the MOS unit once (the screw(E) is loosened even a little), the optical tilt adjustment is required.

When loosen the screw(E), the optical tilt adjustment is necessary at the end of assembling.

(Refer to item "9.3.2.")

To prevent the MOS unit from catching the dust and dirt, do not remove the MOS unit except replacing it.

1. Unscrew the 4 screws(E).
2. Remove the MOS unit.

### IMPORTANT NOTICE:

- The screw (E) is fixed by the screw locking glue with the optical tilt adjustment finished. When remove the MOS unit, wipe the screw locking glue away.
- Don't reuse the screw (E) that the screw locking glue adheres to keep dust or dust or dirt away from the MOS unit. (When installing, use new screw (E).)

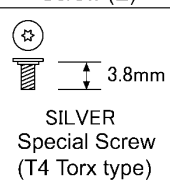
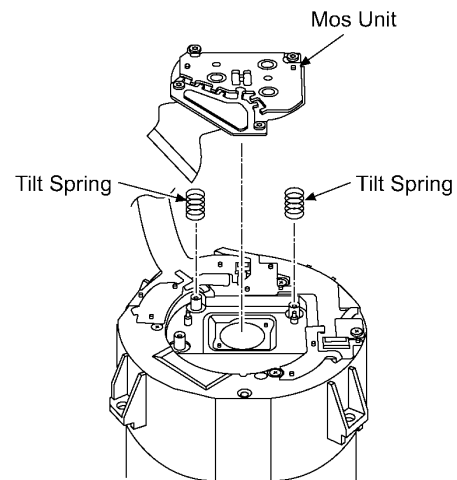
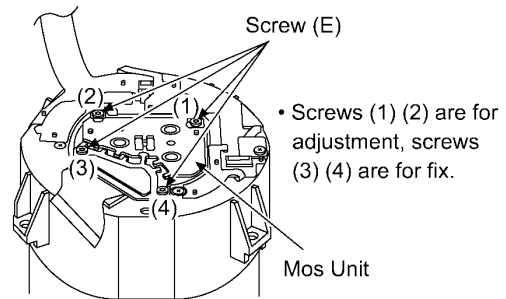

**NOTE: (When Installing)**

- Take new screw.  
(Don't reuse the screw that the screw locking glue adheres.)  
Tighten the screw and the torque according to the following order.  
\*Install adjustment driver's bit in the torque driver.  
Tighten the 4 special screws in order (2)→(1)→(4)→(3).  
Screw torque:  $10 \pm 1 \text{ N}\cdot\text{cm}$ .
- Be sure to execute the optical tilt adjustment with the screw (1) and (2).
- After the adjustment is finished, apply the screw locking glue as shown in the figure below.
- Apply the screw locking glue thinly on the head of screw to the sheet metal with a toothpick.
- Don't apply the screw locking glue where it is applied before disassembling.

Ex)

This is the case where the screw locking glue is applied to the slash area.

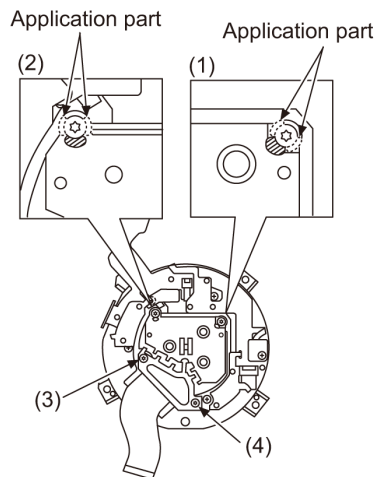

## 9 Measurements and Adjustments

### 9.1. Introduction

When servicing this unit, make sure to perform the adjustments necessary based on the part(s) replaced. Before disassembling the unit, it is recommended to back up the camera data stored in flash-rom as a data file.

**NOTE: (When replacing the Lens unit, Master flange unit and MOS unit)**

- When the MOS unit is unavoidably removed for Lens unit, Master flange unit and MOS unit replaced, an optical adjustment is necessary after parts are exchanged.
- It is necessary to use the “DSC\_Tilt” software to allow the “Optical tilt adjustment”.
- The Adjustment software “DSC\_Tilt” is available at “TSN Website”.

### 9.2. Before Disassembling the unit

#### 9.2.1. Initial Setting Release

The cameras specification are initially set in accordance with model suffix (such as EB, EG, GK, GC, and so on.). Unless the initial setting is not released, an automatic alignment software in the camera is not able to be executed when the alignment is carried out.

**Note:**

The initial setting should be again done after completing the alignment. Otherwise, the camera may not work properly. Therefore as a warning, the camera display a warning symbol “!” on the LCD monitor every time the camera is turned off. Refer to the procedure described in “3.4.2. INITIAL SETTINGS” for details.

**[ How to Release the camera initial setting ]**

**Preparation:**

- Attach the Battery or AC Adaptor with a DC coupler to the unit.  
(Since this unit has built-in memory, it can be performed without inserting SD memory card.)
- Remove the lens cap.

**Step 1. Temporary cancellation of “INITIAL SETTINGS”:**

Set the mode dial to “[ P ] (Program AE mode)”.

While pressing “[ UP ] of Cursor button” and [ MOTION PICTURE ] button simultaneously, turn the Power on.

**Step 2. Cancellation of “INITIAL SETTINGS”:**

Press the [ PLAYBACK ] button, then playback the picture.

Press “[ UP ] of Cursor button” and [ MOTION PICTURE ] button simultaneously. (The camera will beep after this.)

Turn the Power off. (The warning symbol “!” is displayed on the LCD monitor.)

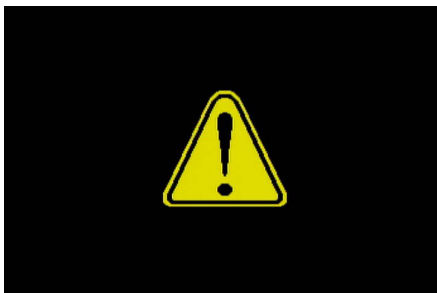

## 9.2.2. Flash-Rom Data Backup

When trouble occurs, it is recommended to backup the Flash-rom data before disassembling the unit.

### [ ROM\_BACKUP (Method of Non-PC backup) ]

1. Insert the SD memory card into the camera.
2. Set the camera to "Temporary cancellation of the initial settings".
3. Select the "SETUP" menu.

From the "SETUP" menu, select "ROM BACKUP".

#### NOTE:

This item is not listed on the customer's "SETUP" menu.

4. When this "ROM\_BACKUP" item is selected, the following submenus are displayed.



Fig.2-1

Item	Function	Details
DSC → SD	Save all the DSC's Flash-rom data to SD memory card	*DSC's Flash-rom data is saved to the SD memory card as a data file by the same format as the TATSUJIN software for the previous models. (DATA BACKUP) -File location: ROOT DIRECTORY in SD memory card. -File Name: 1) User Setup Information data: <Model Number>U.txt [Example: DMC-FX66 : "FX66U.txt"] 2) Optical Adjustment data: <Model Number>F.txt [Example: DMC-FX66 : "FX66F.txt"] *If the concerned file already exists, "OVERWRITE?" message is displayed.
SDALL → DSC (ID CHECK)	Write the all data to DSC's Flash-rom from SD memory card	*The backup data being stored in the SD memory card is transferred to DSC unit. *ID CHECK: When the model ID is different, data is not transferred.
SDALL → DSC (FORCE)	Write the all data to DSC's Flash-rom from SD memory card	*FORCE: Even if the model ID is different, data is transferred. ※If the main PCB is replaced, select "SDALL → DSC (FORCE)".
SDUSER → DSC (FORCE)	Only "User setup information" is written from the saved file in the SD memory card to DSC's Flash-rom.	*Only the user's "setup" setting condition is transferred to DSC unit. *FORCE: Even if the model ID is different, the data is transferred.
! → LUMIX	Shipping set without initializing "User setup information"	*Initial setting is executed without initializing the user's set up setting condition. ※ The initial setting must be perform while the Self-timer LED is blinking, ※ The picture data stored in the built-in memory of the DSC is not erased, with this operation.
ADJFLAG → ALL F	Set all adjustment flags to "F"	*All adjustment flags are set to adjustment completed condition "F".

## 9.2.3. Light Box

If using VFK1164TDVLB Light Box, remove the lens connection ring by loosening three hexagon screws.

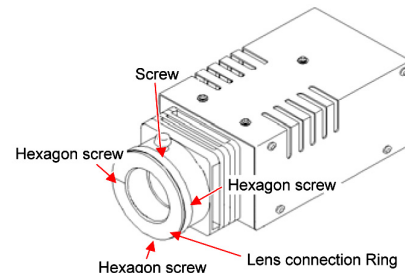

Fig.2-2

## 9.3. Details of Electrical Adjustment

### 9.3.1. How to execute the Electrical Adjustment

It is not necessary to connect the camera to a PC to perform adjustments.

“Flag reset operation” and “Initial setting operation” are required when carrying out the alignment, follow the procedure below.

#### 9.3.1.1. Startup Electrical Adjustment mode

1. Release the initial settings.
2. Insert a recordable SD memory card (32MB or more).  
(Without a SD memory card, the automatic adjustment can not executed.)
3. Procedure to set the camera into adjustment mode:
  - a. Set the mode dial to “[ P ] (Program AE mode)”.
  - b. Turn the Power off.
  - c. Turn the Power on pressing [ MENU/SET ] and [ MOTION PICTURE ] simultaneously.  
LCD monitor displays “SERVICE MODE”.(Refer to Fig. 3-1)

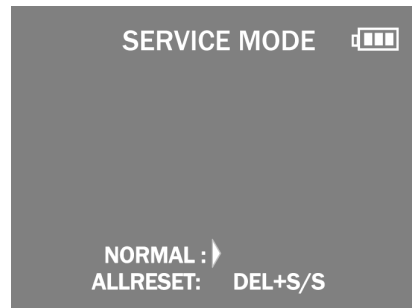

Fig.3-1

#### 9.3.1.2. Status Adjustment Flag Setting

Reset (Not yet adjusted) the status flag condition.

1. After pressing the [ DISPLAY ] button, the LCD monitor displays the Flag status screen (Refer to Fig.3-2)
2. Select item by pressing the Cursor buttons. (Gray cursor is moved accordingly.)
3. Press the [ Delete ] button.

**NOTE:**

The selected item's flag has been changed from “F (green)” to “0 (yellow)”.

\*Flag conditions:

F (green)

means that the alignment has been completed and the status flag condition is set. In this case, the flag condition should be reset, if you try to carry out the automatic alignment.

0 (yellow)

means that the alignment has been not “completed” and the status flag condition is “reset”. In this case, automatic alignment is available.

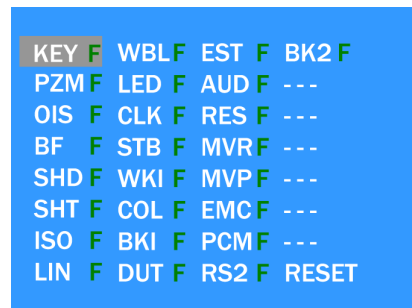

Fig.3-2

- In case of setting the status flag into set condition again without completion of the alignment, the status flag should be UNDO by using ROM BACKUP function.

### 9.3.1.3. Execute Adjustment (In case of “OIS Adjustment”)

1. Perform step “9.3.1.1.” to “9.3.1.2.”, to reset the OIS flag status “F” (Set) to “0” (Reset)
2. Press [ DISPLAY ] button after Flag reset.  
OIS Adjustment screen is displayed on the LCD panel.  
(Refer to Fig.3-3)
3. Press the [ Shutter ] button. The adjustment will start automatically.

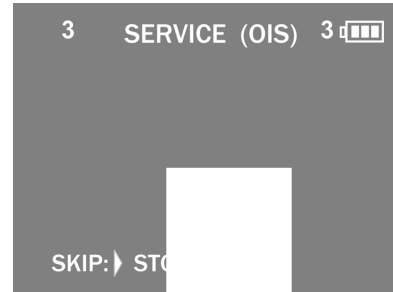

Fig.3-3

4. When the adjustment is completed successfully, adjustment report menu appears with Green OK on the LCD monitor. (Refer to Fig.3-4)

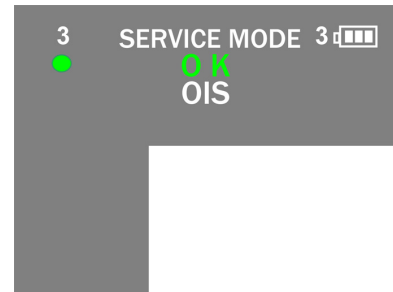

Fig.3-4

### 9.3.1.4. Attention point during Adjustment

1. Step “9.3.1.3.” procedure shows OIS adjustment as an example. To perform the adjustment, refer to the “9.3.2. Adjustment Specifications” table which shows key point for each adjustment.
2. Do not move the light box, the camera or the chart while adjusting. If one of these is moved accidentally, start the adjustment again.
3. Do not press any buttons/keys until the default menu (Fig.3-5) is displayed on the LCD monitor. Otherwise, adjustment data may not be stored properly.
4. If the adjustment is interrupted accidentally, the alignment data may not be properly saved in the Flash-rom.

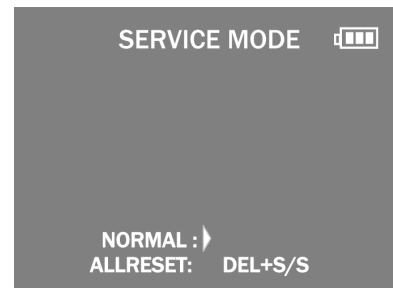

Fig.3-5

### 9.3.1.5. Finalizing the Adjustment

1. Several adjustment flags can be reset (“F” into “0”) at the same time. In this case, when the adjustment has been completed, the screen will change showing the adjustment for the next item until all reset items are completed.  
Also, when the shutter button is pressed, the screen jump to the next adjustment item.
2. To cancel the adjustment mode while in the process of performing the adjustment, follow this procedures.
  - (1) Press [ Delete ] button.
  - (2) Press [ RIGHT ] of Cursor button.

**NOTE:**

- If adjustment is cancelled with above procedure, adjustment is not completed. Make sure to adjust it later.

### 9.3.2. Adjustment Specifications

The following matrix table shows the relation between the replaced part and the Necessary Adjustment. When a part is replaced, make sure to perform the necessary adjustment(s) in the order indicated. The table below shows all the information necessary to perform each adjustment.

Adjustment order	Adjustment Item	FLAG	Purpose	Replacing Parts						JIG/TOOLS	SET UP	How to Operate
				MAIN P.C.B.	VENUS ENGINE (IC6001)	FLASH ROM (IC6005)	Lens part (Excluding MOS SENSOR)	MOS SENSOR UNIT	GYRO (IC7101)			
1	Optical Tilt	—	Align the image sensor installation angle to the Lens.	—	—	—	○	○	—	NOTE: -It is necessary to use the "DSC_Tilt" software to allow the "Optical tilt adjustment". -The Adjustment software "DSC_Tilt" is available at "TSN Website". -Optical Axis Adjustment Driver (RFKZ0569):T4		
2	Venus Zoom	PZM	Venus Zoom Inspection	○	○	○	—	—	—	NONE	NONE	1)Press Shutter Button 2)After completed, the "OK" menu appears.
3	OIS sensor	OIS	OIS sensor output level adjustment	○	○	○	○	—	—	NONE	NONE	1)Press Shutter Button 2)After completed, the "OK" menu appears.
4	Backfocus / GYRO	BF	To have the focus tracking curve be appropriate shape and GYRO sensor adjustment	○	○	○	○	○	※1	-COLLIMATOR (RFKZ0422)	1)Set the camera in front of collimator so that the distance from collimator to camera becomes about 6 cm as shown in Fig. A. [NOTE] Please notice ! "NG" might happen while auto adjusting. - Do not put the black colored stuff at the back side of collimator near hunching chart to get some certain brightness. - Make sure the hunching chart has no dust and dirty condition.	1)Press Shutter Button (Do not apply any shock and vibration for the camera while adjusting) (Green ● mark is displayed on LCD). 2)A star chart changes into the state where it is reflected to the center. 3)Press shutter button, again. 4)After completed, the "OK" message appears.
5	Shutter	SHT	Shutter speed adjustment	○	○	○	○	○	—	-LIGHT BOX (RFKZ0523) (VFK1164TDVLB)	1) Set the camera in front of LIGHTBOX so that the distance from LIGHTBOX to camera becomes about 8.5 cm as shown in Fig. B. 2) Set the camera angle so that the diffusing surface of LIGHTBOX is displayed on the center of LCD monitor. [NOTE] - Since the lens position is automatically set into certain position after executing auto adjustment, confirm the angle after stopping the lens zoom position. - It is no problem even though the chart on to the LCD monitor slightly cut at the corner. - It is no problem even though the focusing slightly becomes out of focusing condition. - Not connect the USB cable at this stage.	1)Press Shutter Button 2)After completed, the "OK" menu appears.
6	ISO	ISO	ISO sensitivity adjustment	○	○	○	○	○	—		1) Insert the TR chart into the slot of LIGHTBOX as shown in Fig. C. 2) Set the camera in front of LIGHTBOX so that the distance from LIGHTBOX to camera becomes about 8.5 cm as shown in Fig. B. 3) Set the camera angle so that the center of chart is displayed on the center of LCD monitor. [NOTE] - Since the lens position is automatically set into certain position after executing auto adjustment, confirm the angle after stopping the lens zoom position. - It is no problem even though the chart on to the LCD monitor slightly cut at the corner. - It is no problem even though the focusing slightly becomes out of focusing condition. - Not connect the USB cable at this stage.	1)Press Shutter Button 2)After completed, the "OK" menu appears.
7	High brightness coloration	LIN	High brightness coloration adjustment	○	○	○	○	○	—	-LIGHT BOX (RFKZ0523) (VFK1164TDVLB) -TR CHART (RFKZ0443)		1)Press Shutter Button 2)After completed, the "OK" menu appears.
8	White Balance	WBL	White balance adjustment under various color temperature	○	○	○	○	○	—			1)Press Shutter Button 2)After completed, the "OK" menu appears.
9	Flash adjustment	STB	Flash adjustment	○	○	○	—	—	—	NONE	NONE	1)Open the built in Flash. 2)Press Shutter Button. (Do not apply any shock and vibration for the camera while adjusting) 3)Check that a flash shines. (It is different for every model how many times it shines.) ※When a flash does not shine, there is a possibility that the flash unit is out of order. 4)Check a test result. ※Results of the tests are usually NG. (When a result is OK, it is the completion of an inspection.) 5)When a result is NG, rewrite STB flag to "F" (adjustment completed) using ROM_BACKUP function.  ※The flag "STB" is an item which checks shines operation of a flash automatically at a Manufacturing facility. For this reason, Except environment for exclusive use, a result will be NG, but it is no problem if shines operation can be checked visually.



Adjustment order	Adjustment Item	FLAG	Purpose	Replacing Parts						JIG/TOOLS	SET UP	How to Operate
				MAIN P.C.B.	VENUS ENGINE (IC6001)	FLASH ROM (IC6005)	Lens part (Excluding MOS SENSOR)	MOS SENSOR UNIT	GYRO (IC7101)			
10	MOS SENSOR Missing Pixels (White) ※2	WKI	Compensation of MOS SENSOR Missing Pixels (White)	○	○	○	—	○ ※1	—	NONE	NONE	1) Press Shutter Button 2) After completed, the "OK" menu appears.
11	Color reproduction inspection and Microphone check	COL	Color reproduction inspection and Microphone check	○	○	○	○	○	—	NONE	NONE	1) While speaking into the microphone, press Shutter Button (When zooming started, stop speaking.) 2) After completed, the "OK" menu appears.
		BKI	Do not use "BK1" adjustment flag for this unit. Use "BK2" adjustment flag, instead. (In case of most DSC models, the adjustment flag for MOS SENSOR Missing Pixels is "BK1". But, in this model, "BK2" the adjustment flag for MOS SENSOR Missing Pixels.)									
12	MOS SENSOR Missing Pixels (Black) ※3	BK2	Compensation of MOS SENSOR Missing Pixels (Black)	○	○	○	—	○ ※1	—	-LIGHT BOX RFKZ0523 (VFK1164TDVLB) -DIFFUSER RFKZ0591	1) Prepare the LIGHTBOX (RFKZ0523). (The LIGHTBOX "VFK1164TDVLB" can be used if the front hood of VFK1164TDVLB is removed.) 2) Set the DIFFUSER to diffusing surface of LIGHTBOX.  NOTE: Do not use "BK1" adjustment flag for this unit. Use "BK2" adjustment flag, instead.	1) While no object between the LIGHTBOX and Camera, press the Shutter Button. (The lens starts zooming and stops automatically, then green ● mark is displayed on LCD). 2) Set the LIGHTBOX and Camera (the edge of Lens ring front) so that distance becomes about 2.3 cm. (Refer to Fig. B) And, press the Shutter Button. (The 1st adjustment is executed, and then green ● mark is displayed on LCD). 3) While no object between the LIGHTBOX and Camera, press the Shutter Button. (The green ● mark is displayed on LCD). 4) Set the LIGHTBOX and Camera (the edge of Lens ring front) so that distance becomes about 5.5 cm. (Refer to Fig. B) And, press the Shutter Button. (The 2nd adjustment is executed, and then green ● mark is displayed on LCD). 5) While no object between the LIGHTBOX and Camera, press the Shutter Button. (The green ● mark is displayed on LCD). 6) Set the LIGHTBOX and Camera (the edge of Lens ring front) so that distance becomes about 6 cm. (Refer to Fig. B) And, press the Shutter Button. (The 3rd adjustment is executed, and then OK mark is displayed on LCD when the adjustment has been completed successfully.)

※1: Execute the adjustment when remove the MOS unit and replace the MOS unit.

※2: The pixel that always lights while shaded is called a white wound.

※3: The pixel that does not light while complete exposed is called a black wound.

\*This unit does not have the LCD adjustment of the camera (LCD flicker adjustment etc.).

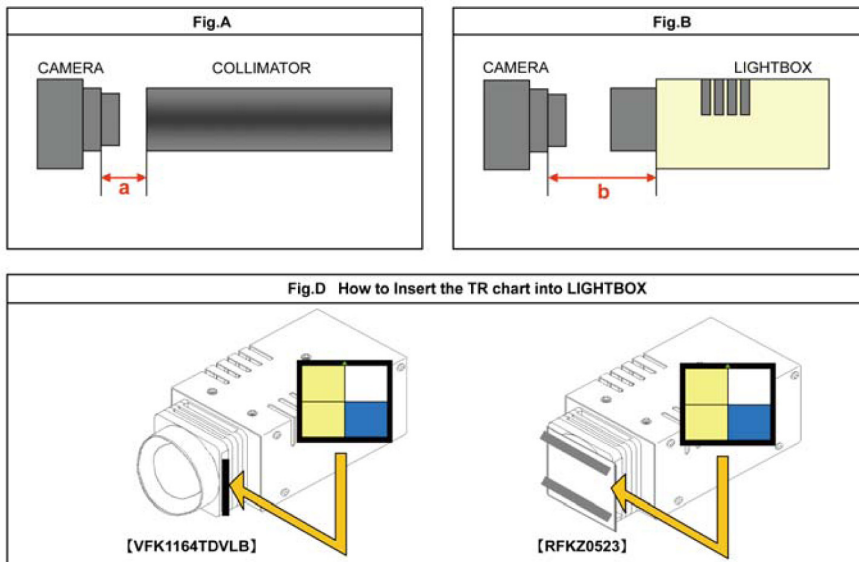

■ **IMPORTANT NOTICE** (After replacing the MAIN P.C.B.)  
 After replacing the MAIN P.C.B., make sure to perform the "INITIAL SETTINGS" first, then release the "INITIAL SETTINGS" in order to proceed the electrical adjustment.

NOTE:

- 1). If electrical adjustment or data re-writing is executed before "INITIAL SETTINGS", suffix code list is never displayed, and it cannot be chosen suitable suffix code.
- 2). Never remove the battery during initial setting in process.

## 9.4. After Adjustment

### 9.4.1. Initial Setting

Since the initial setting has been released to execute the built-in adjustment software, it should be set up again before shipping the camera to the customer.

Refer to the procedure described in "3.4.2. INITIAL SETTINGS" for details.

#### [ IMPORTANT ]

1. The initial setting should be done again after completing the alignment. Otherwise, the camera will not work properly. Therefore as a warning, the camera display a warning symbol "!" on the LCD monitor every time the camera is turned off.
2. Confirm that status of all adjustment flag show "F". Even if one of the adjustment flag shows "0", initial setting programmed is never executed.

# 10 Maintenance

## 10.1. Cleaning Lens, Viewfinder and LCD Panel

Do not touch the surface of lens, Viewfinder and LCD Panel with your hand.

When cleaning the lens, use air-Blower to blow off the dust.

When cleaning the LCD Panel, dampen the lens cleaning paper with lens cleaner, and the gently wipe the its surface.

**Note:**

The Lens Cleaning KIT ; VFK1900BK (Only supplied as 10 set/Box) is available as Service Aid.

# 11 Block Diagram

## 11.1. Overall Block Diagram

OVERALL BLOCK DIAGRAM

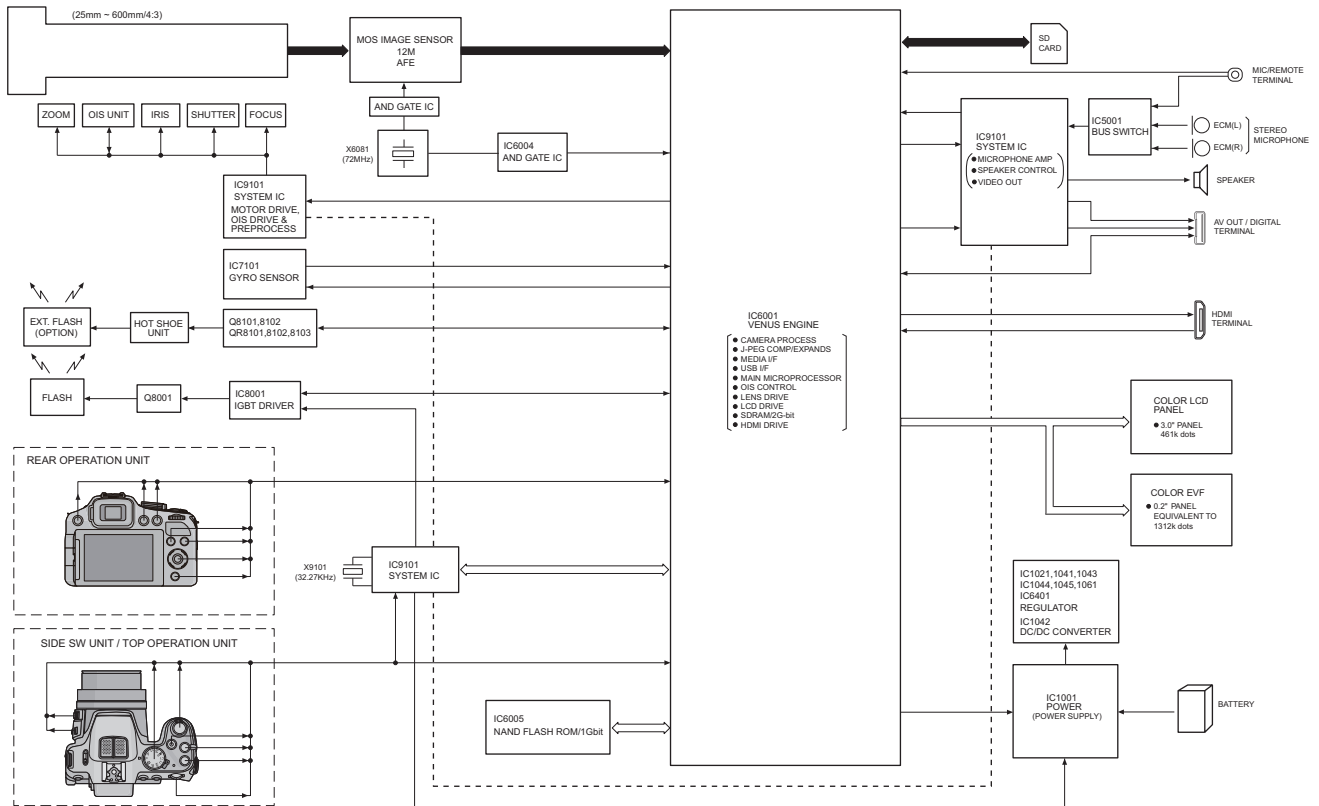

DMC-FZ200 OVERALL BLOCK DIAGRAM

## 11.2. System Control Block Diagram

SYSTEM CONTROL BLOCK DIAGRAM

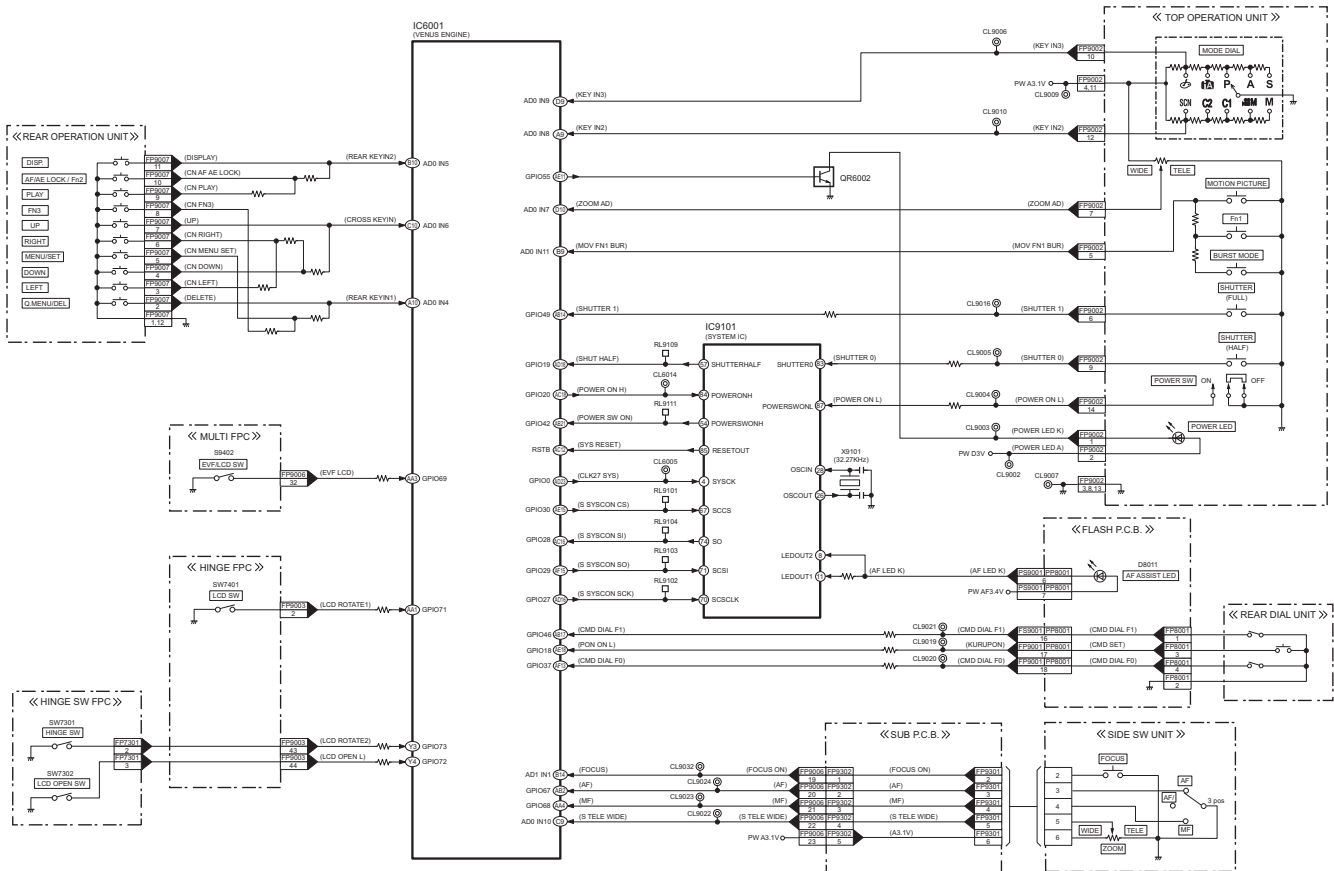

DMC-FZ200 SYSTEM CONTROL BLOCK DIAGRAM

### 11.3. Video/Audio Process Block Diagram

VIDEO/AUDIO PROCESS BLOCK DIAGRAM

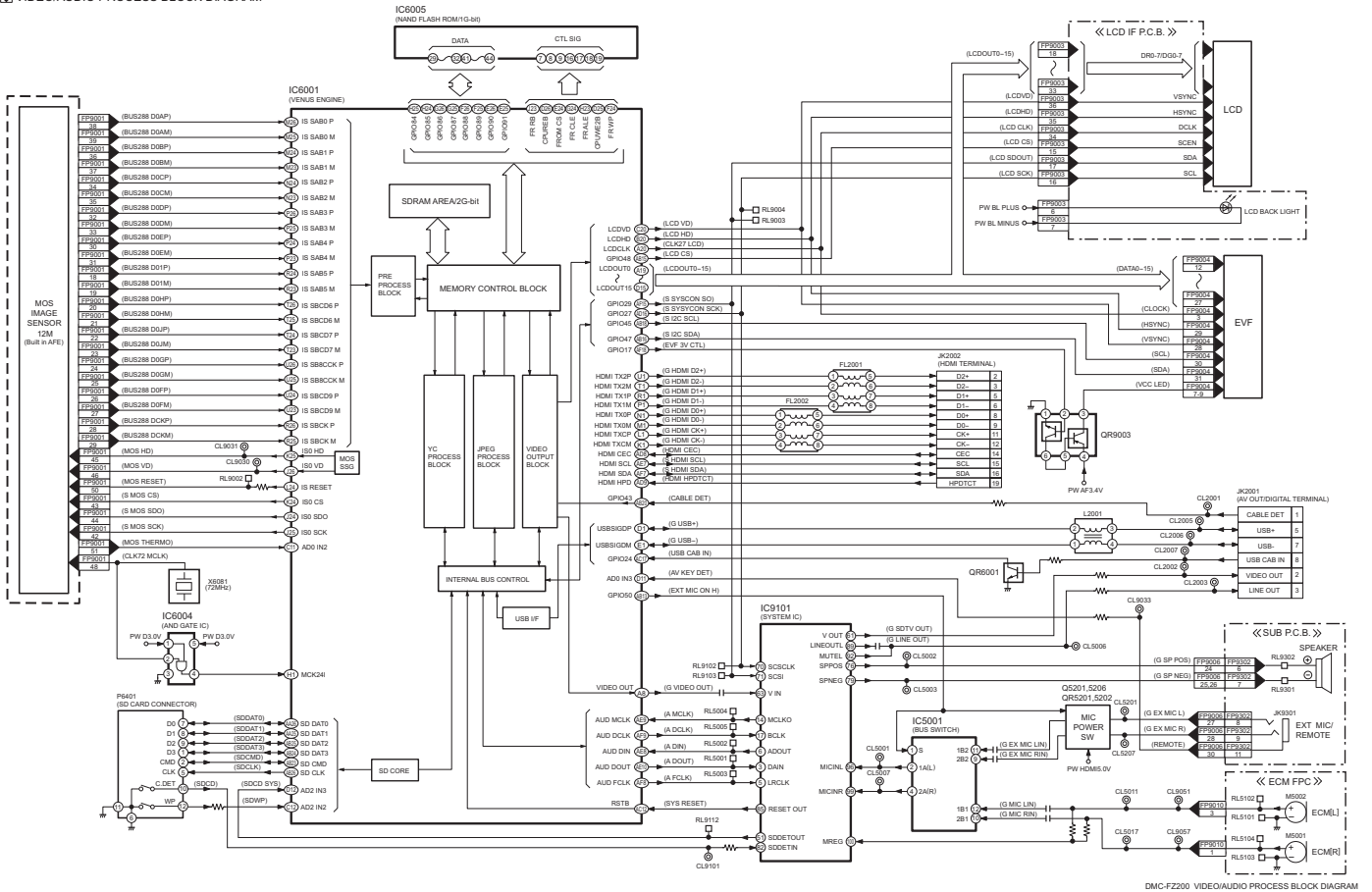

### 11.4. Lens/Flash Block Diagram

LENS/FLASH BLOCK DIAGRAM

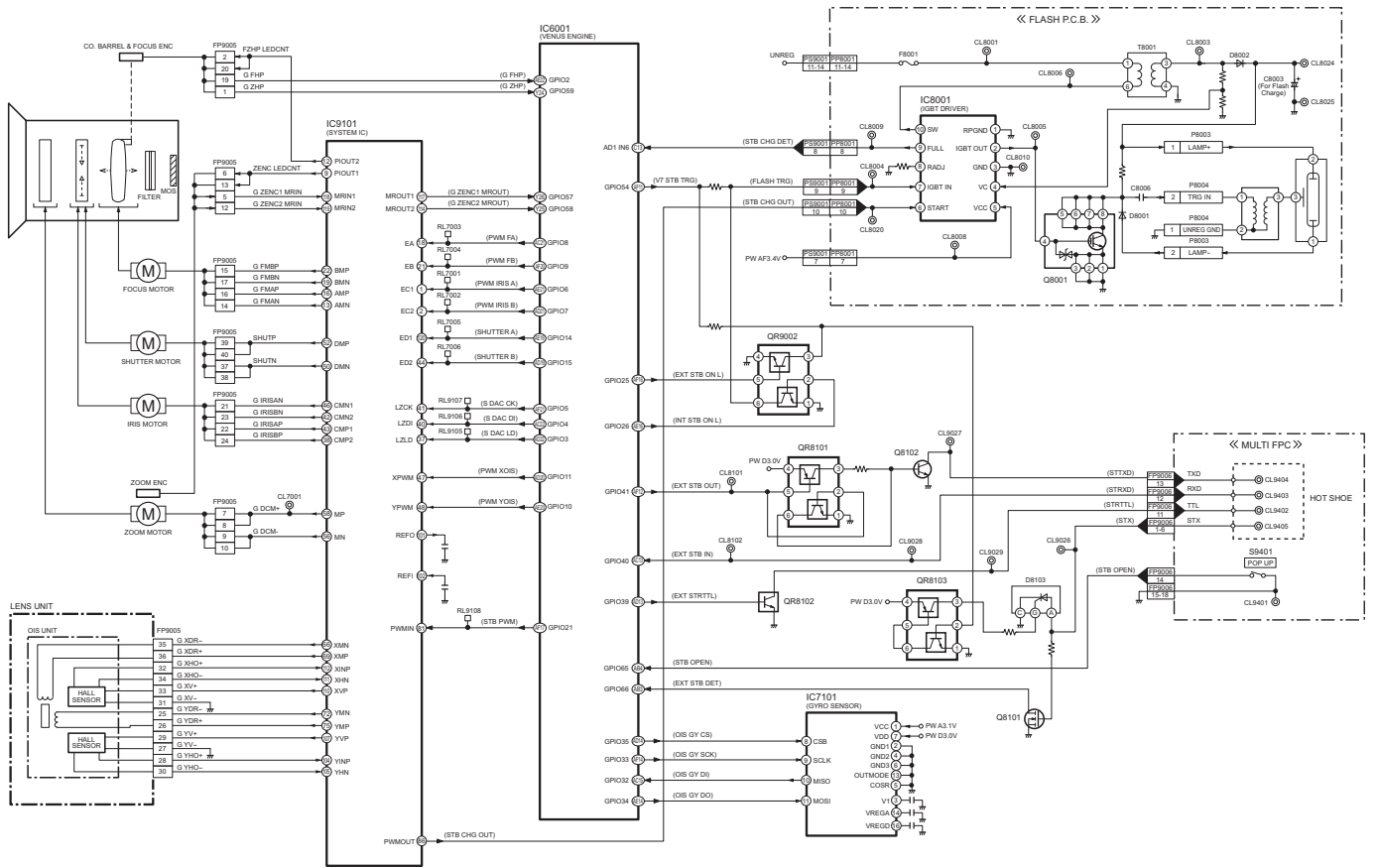

DMC-F2200 LENS/FLASH BLOCK DIAGRAM

## 11.5. Power Block Diagram

### POWER BLOCK DIAGRAM

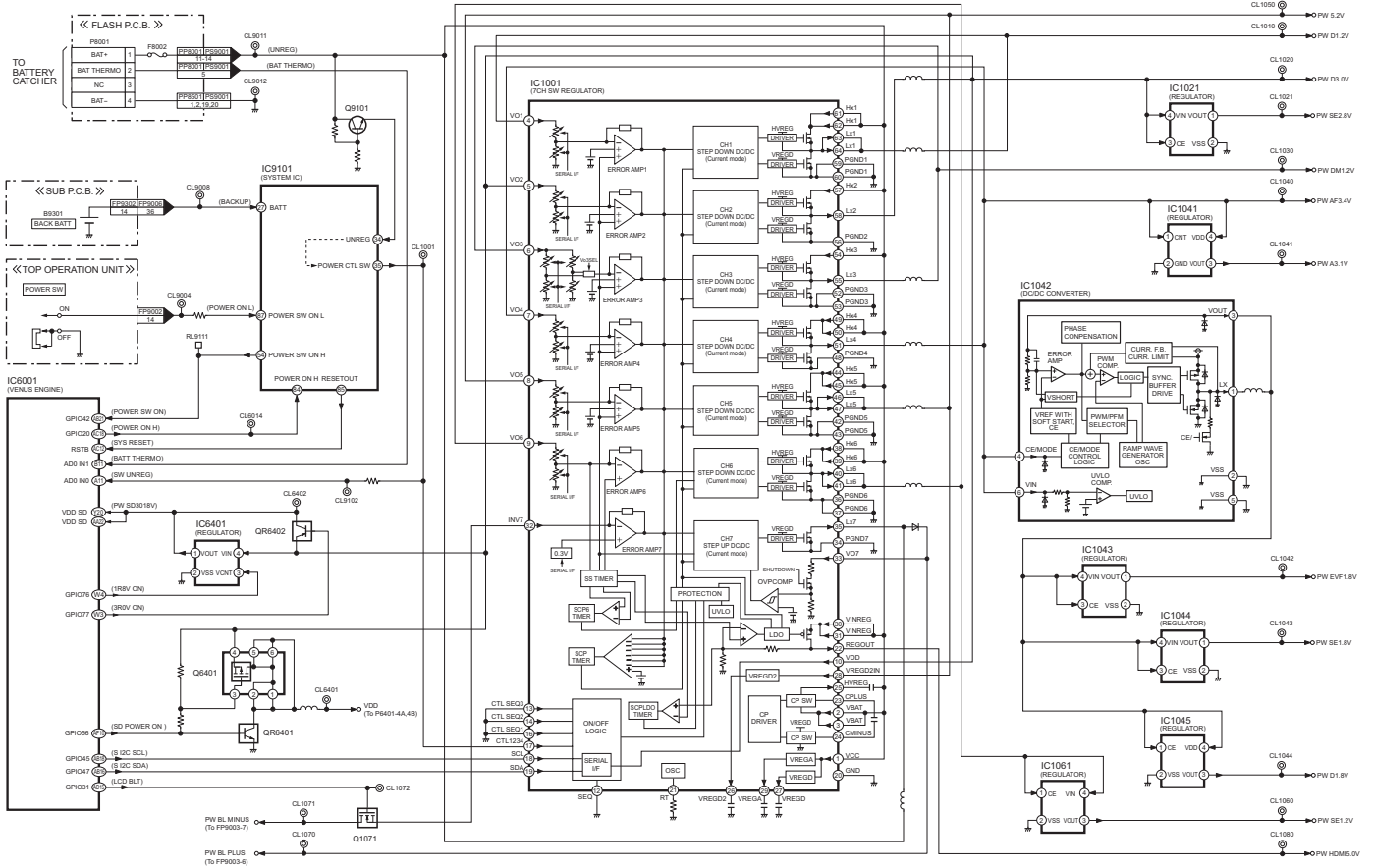

DMC-FZ200 POWER BLOCK DIAGRAM



# 12 Wiring Connection Diagram

## 12.1. Interconnection Diagram

INTERCONNECTION DIAGRAM

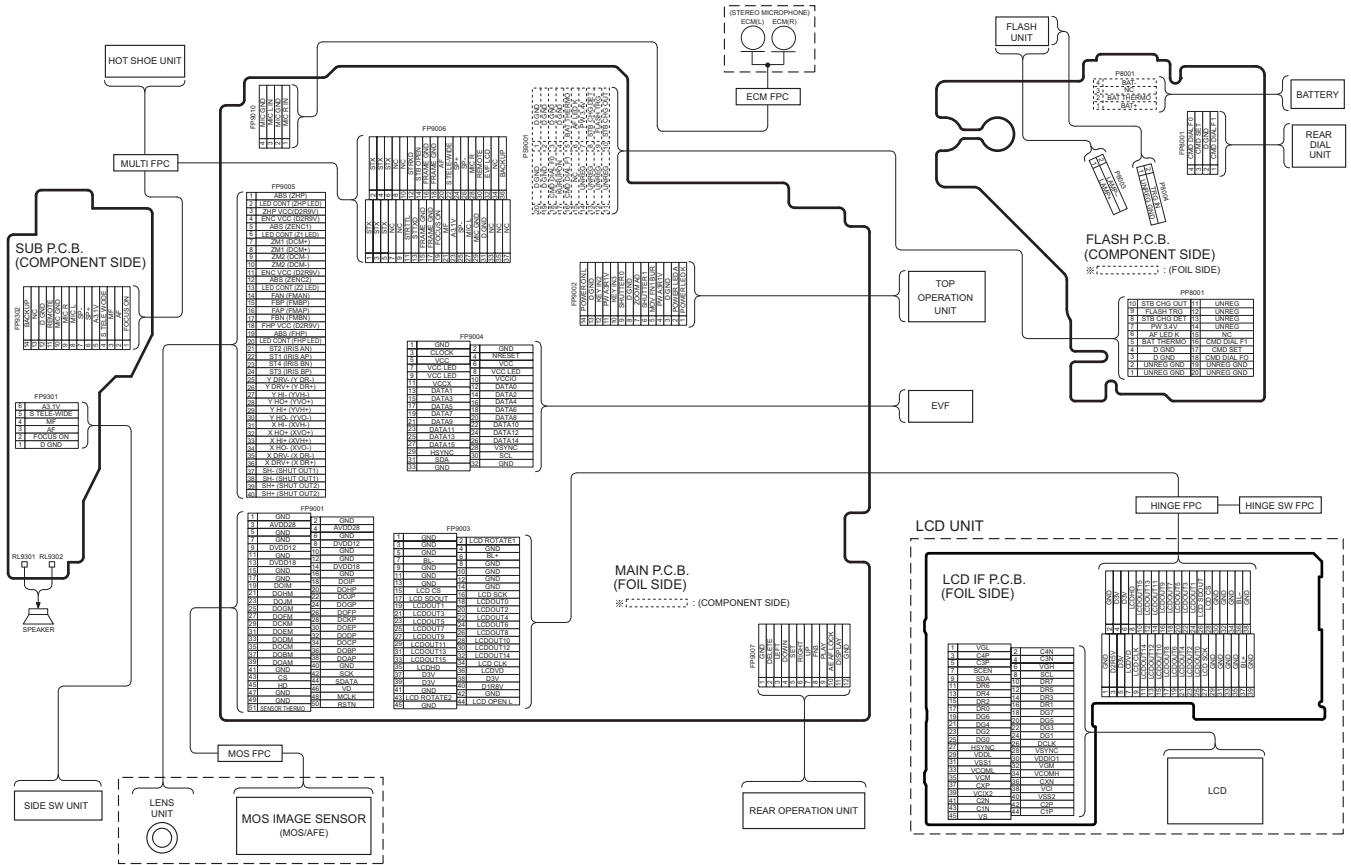

DMC-FZ200 INTERCONNECTION DIAGRAM

**IMPORTANT SAFETY NOTICE:**

COMPONENTS IDENTIFIED WITH THE MARK ⚠ HAVE THE SPECIAL CHARACTERISTICS FOR SAFETY. WHEN REPLACING ANY OF THESE COMPONENTS USE ONLY THE SAME TYPE.

- 1.Although reference number of the parts is indicated on the P.C.B. drawing and/or schematic diagrams, it is NOT mounted on the P.C.B. when it is displayed with "\$" mark.
- 2.It is only the "Test Round" and no terminal (Pin) is available on the P.C.B. when the TP (Test Point) indicated as "●" mark.
- 3.Use the parts number indicated on the Replacement Parts List .
- 4.Indication on Schematic diagrams:

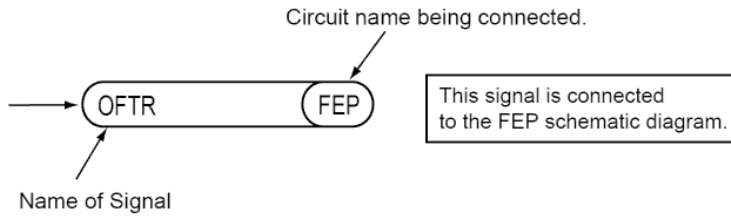

5. It might be taking time for display and/or access of the Schematic Diagrams & P. C. B having the heavy data volume.

- Note: 1.\* Be sure to make your orders of replacement parts according to this list.
2. IMPORTANT SAFETY NOTICE  
Components identified with the mark  $\triangle$  have the special characteristics for safety.  
When replacing any of these components, use only the same type.
3. Unless otherwise specified,  
All resistors are in OHMS, K=1,000 OHMS. All capacitors are in MICRO-FARADS (uf), P=uuF.
4. The marking (RTL) indicates the retention time is limited for this item. After the discontinuation of this assembly in production, it will no longer be available.
5. Supply of CD-ROM, in accordance with license protection, is allowable as replacement parts only for customers who accidentally damaged or lost their own.

E.S.D. standards for Electrostatically Sensitive Devices, refer to “PREVENTION OF ELECTROSTATIC DISCHARGE (ESD) TO ELECTROSTATICALLY SENSITIVE (ES) DEVICES” section.

**Definition of Parts supplier:**

1. Parts marked with [ENERGY] in the remarks column are supplied from Panasonic Corporation Energy Company.
2. Parts marked with [PAVCX] in the remarks column are supplied from PAVCX.  
Others are supplied from AVC-CSC-SPC.

**Model No. : DMC-FZ200 Power (P) (Main P.C.B.)**

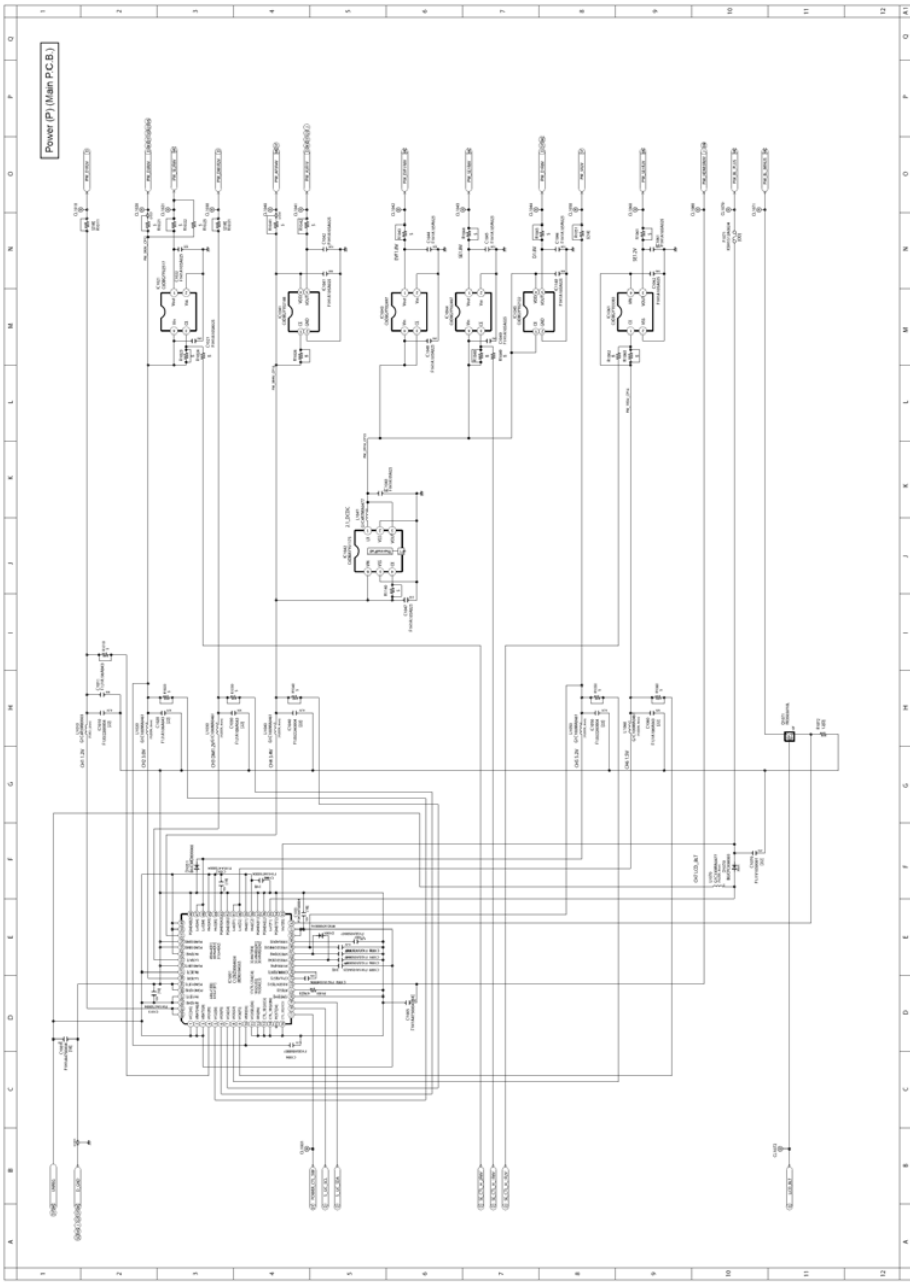

**Model No. : DMC-FZ200 Jack (J) (Main P.C.B.)**

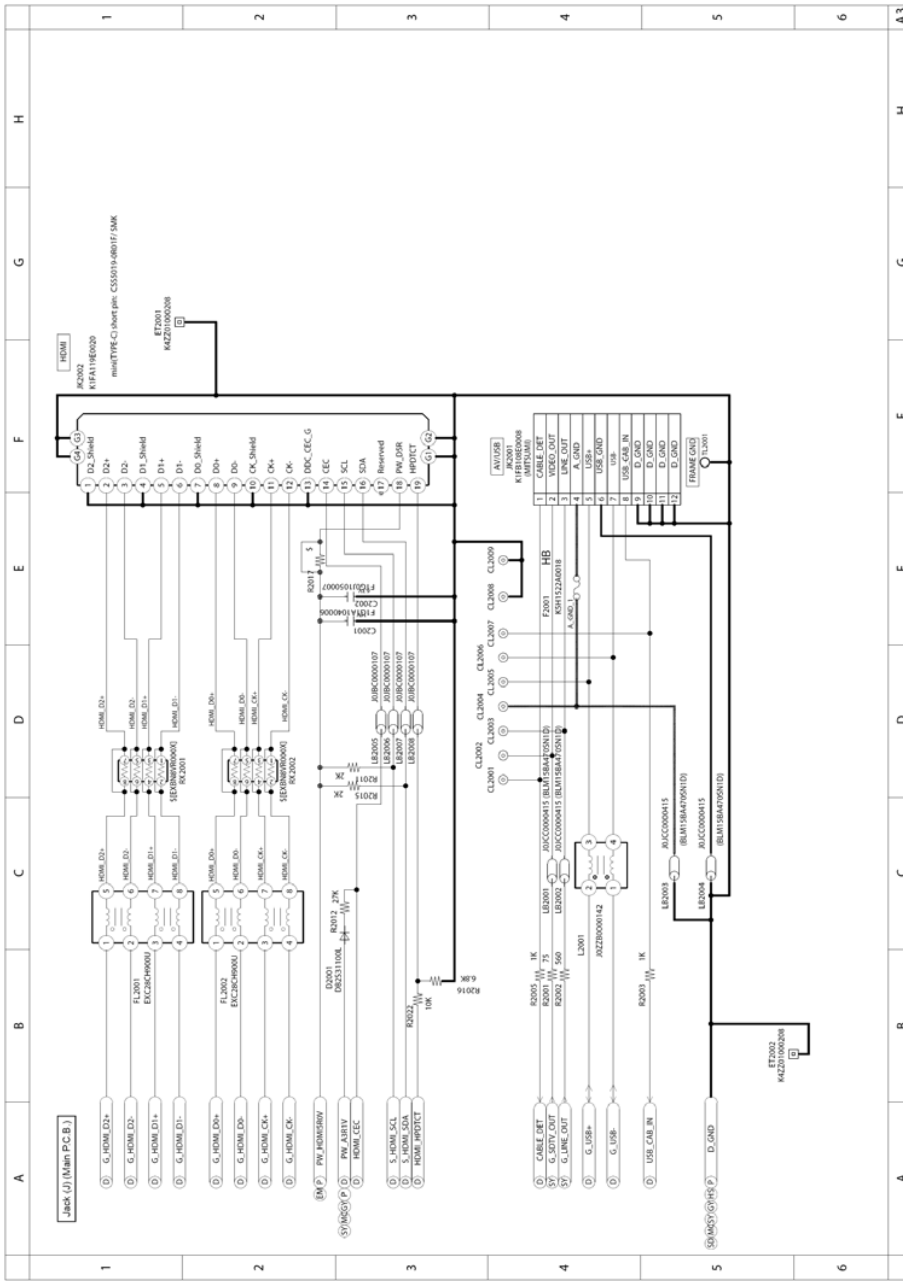

**Model No. : DMC-FZ200 EXT MIC (EM) (Main P.C.B.)**

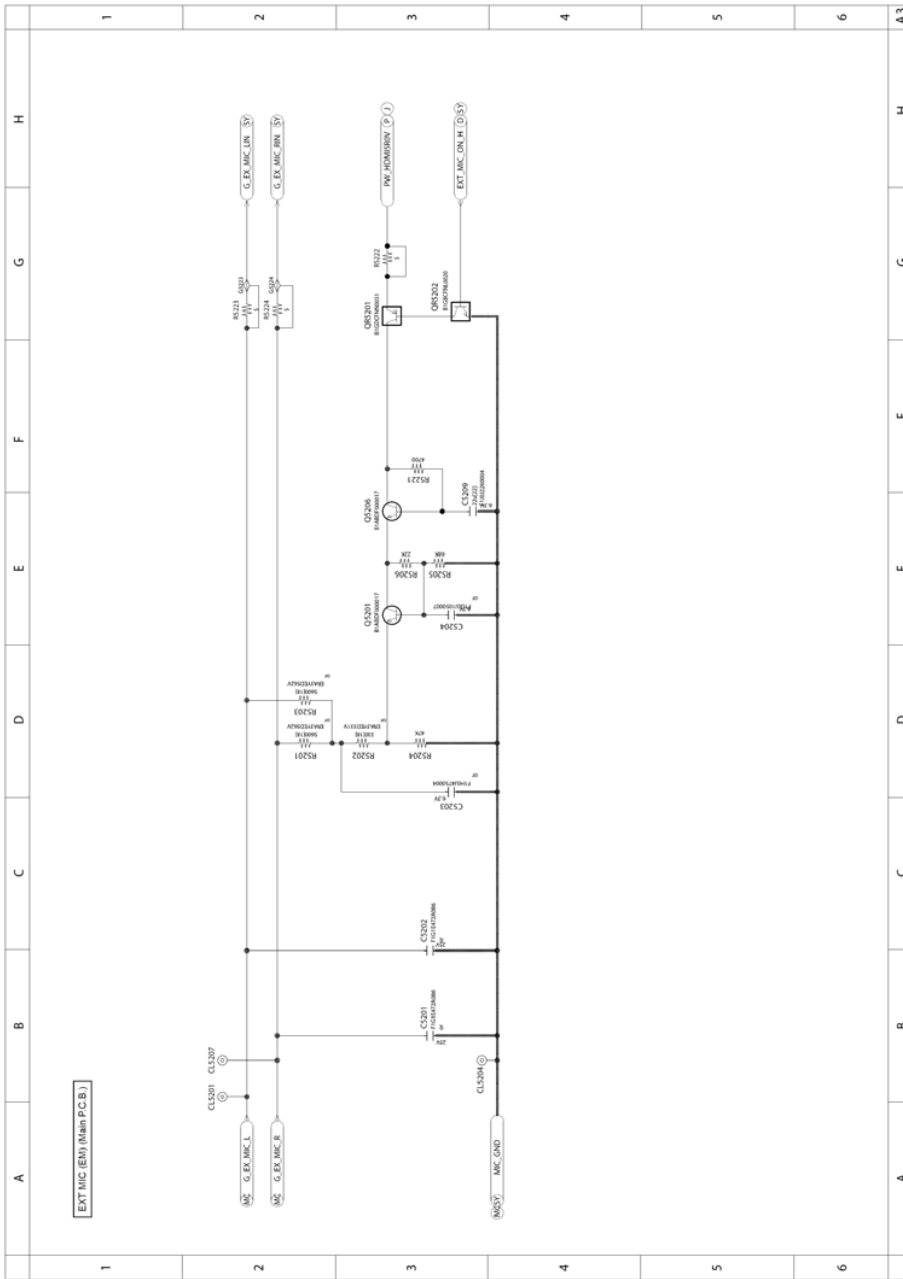

**Model No. : DMC-FZ200 Digital (D) (Main P.C.B.)**

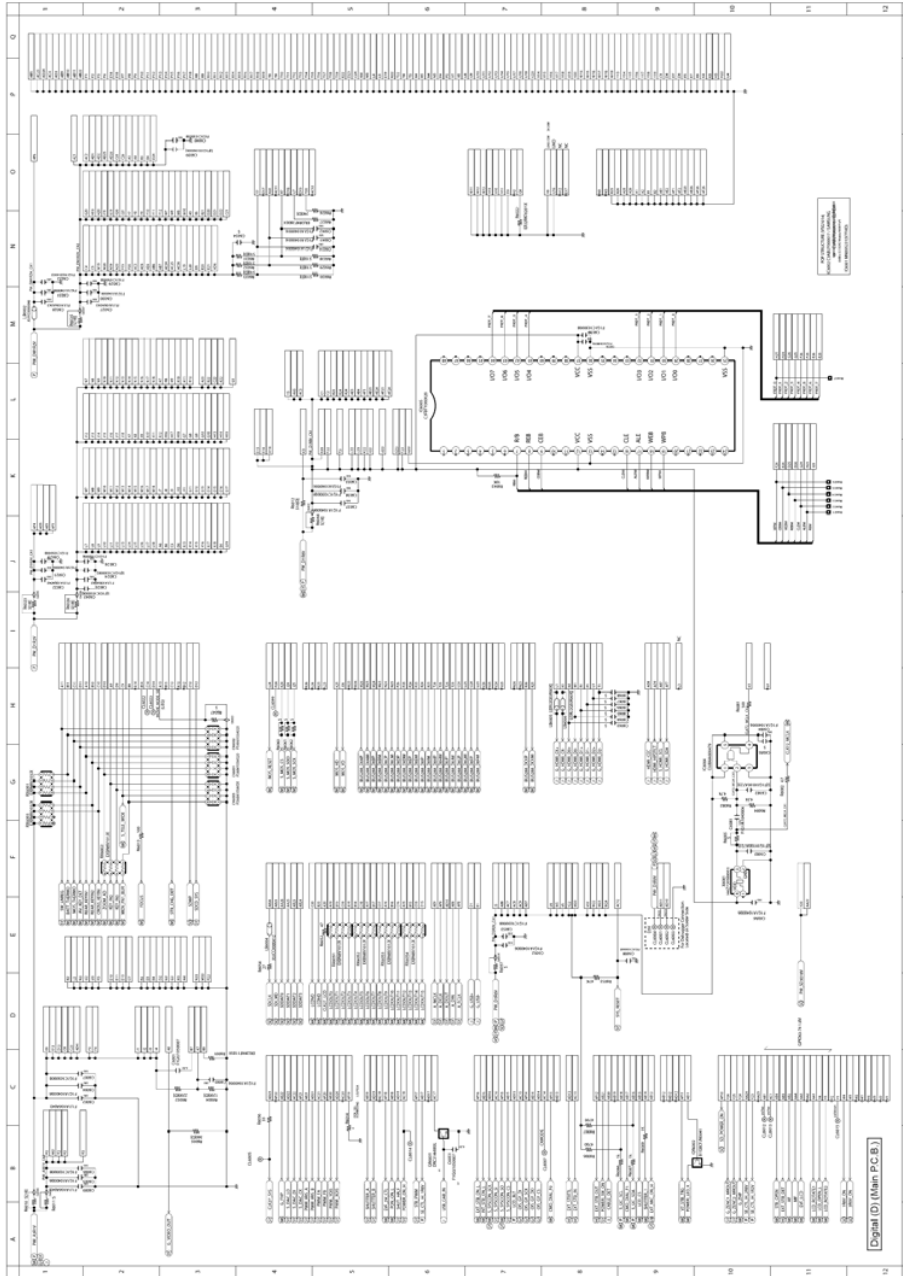

**Model No. : DMC-FZ200 SD Card (SD) (Main P.C.B.)**

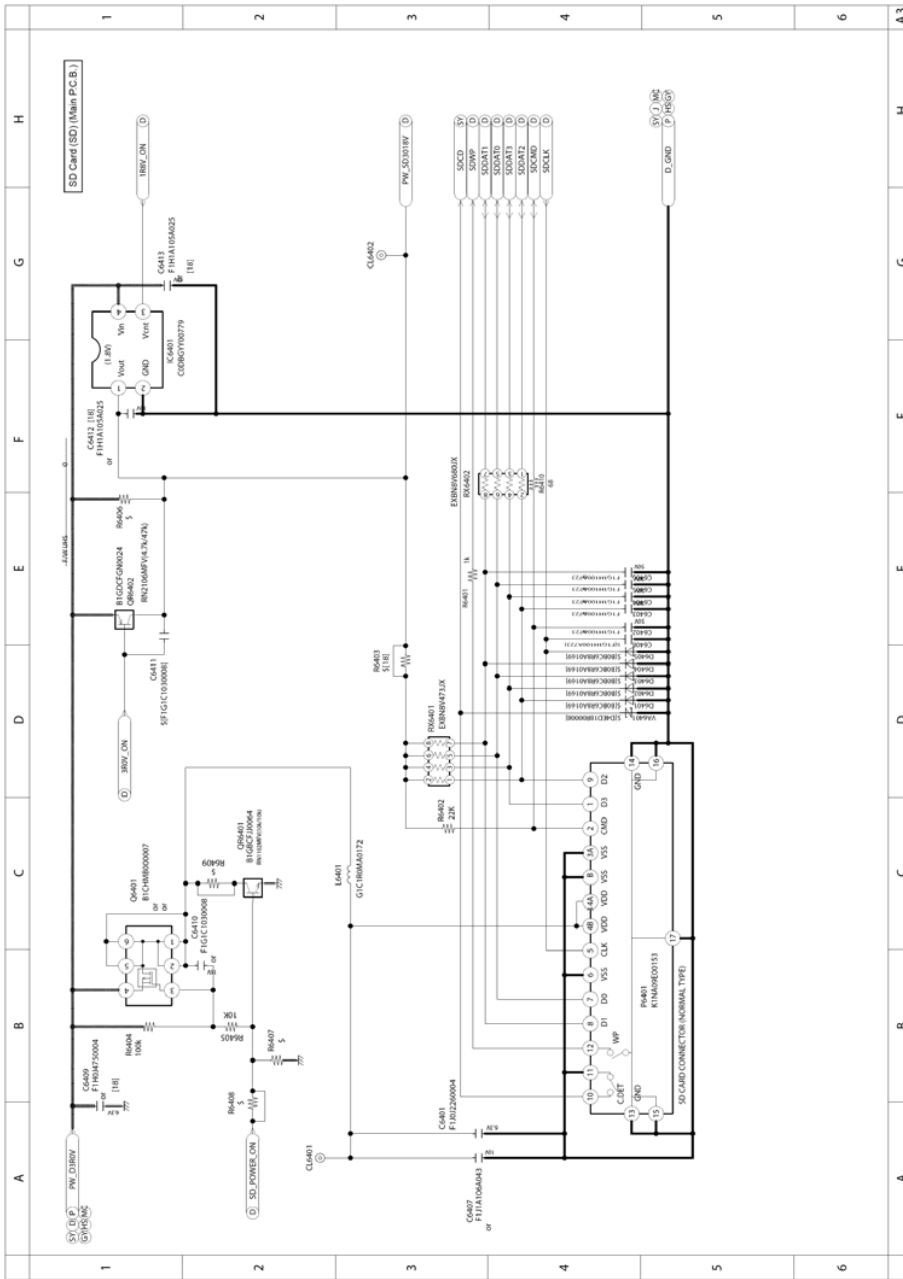





**Model No. : DMC-FZ200 Hot Shoe (HS) (Main P.C.B.)**

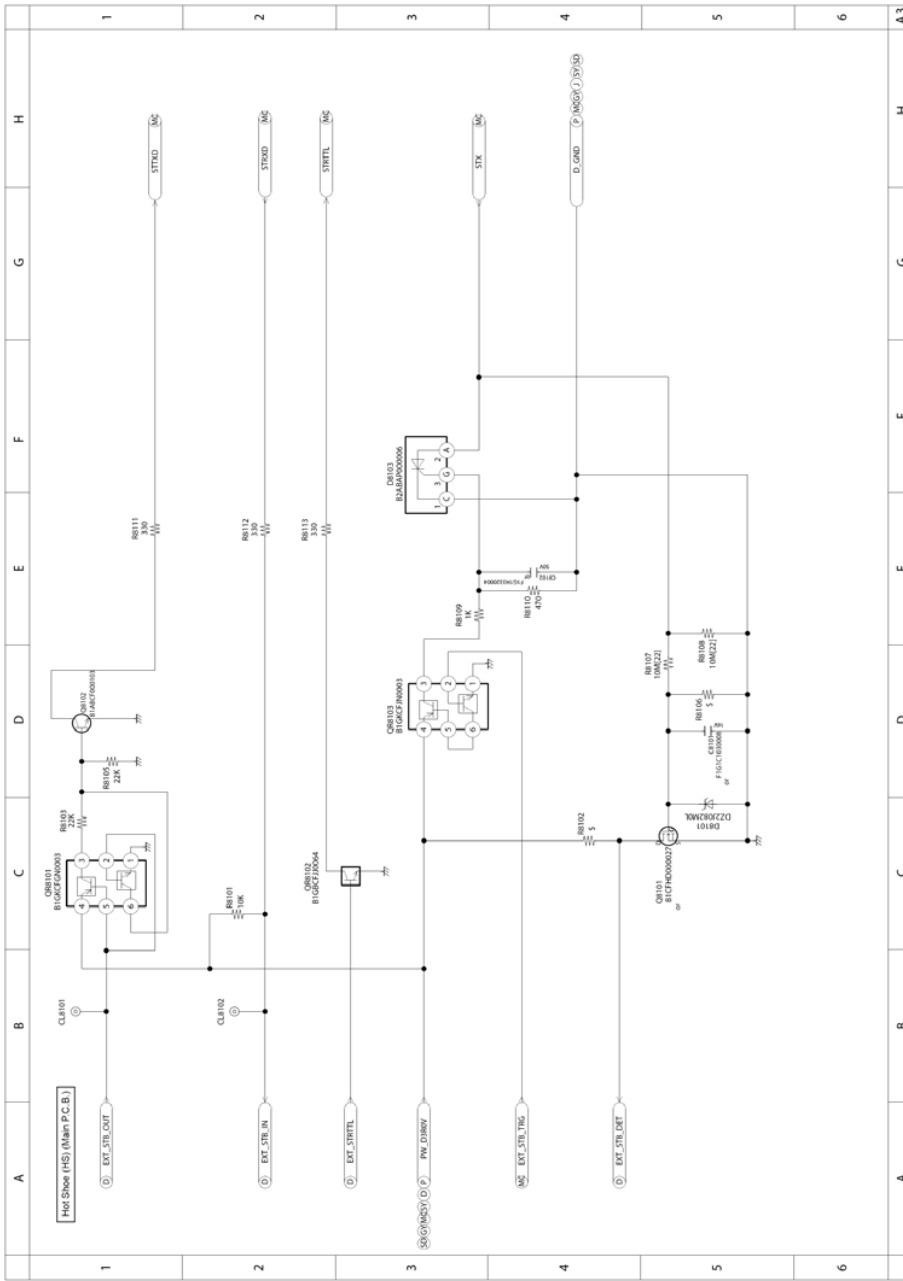

**Model No. : DMC-FZ200 Main Connection (MC) (Main P.C.B.)**

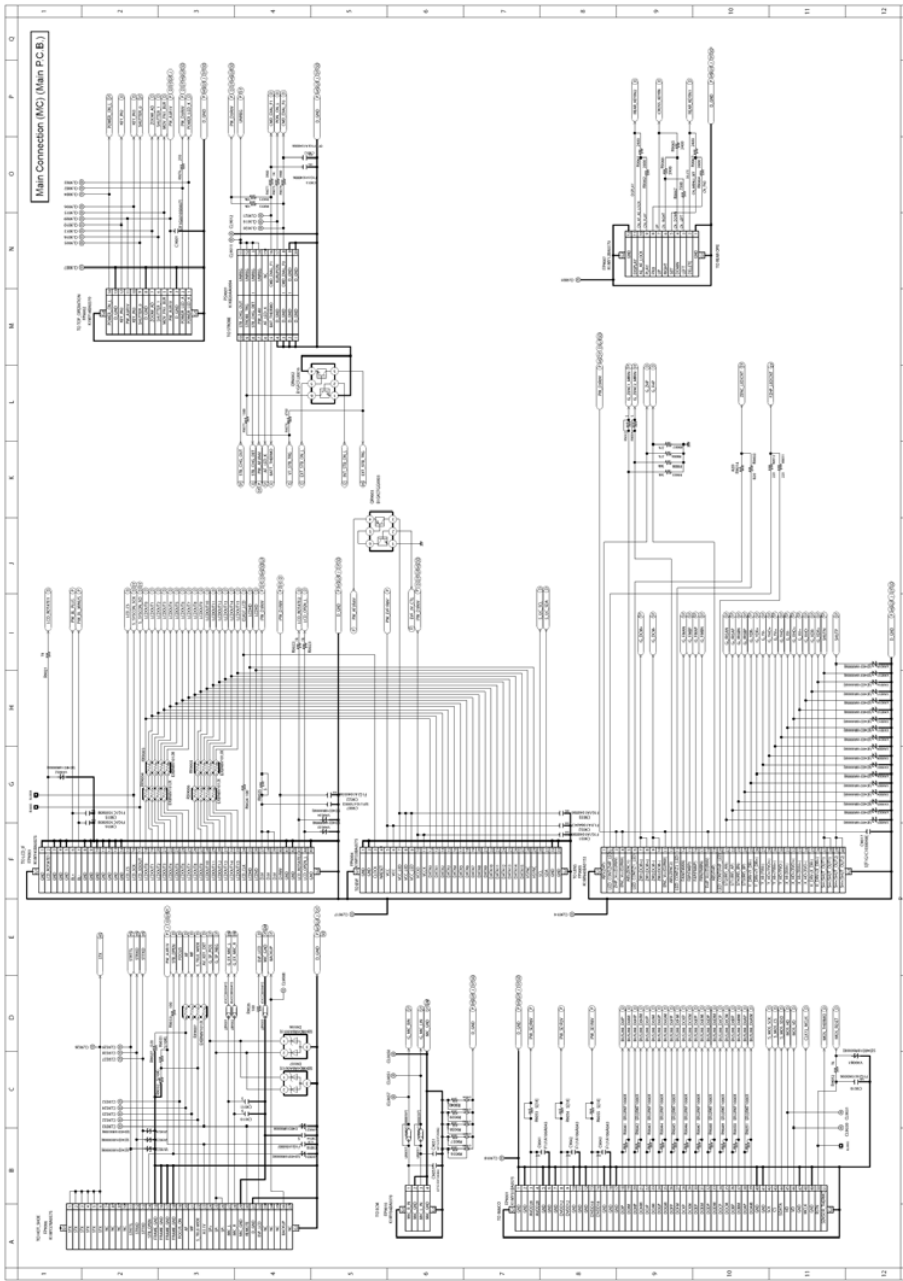

# Model No. : DMC-FZ200 System Driver (SY) (Main P.C.B.)

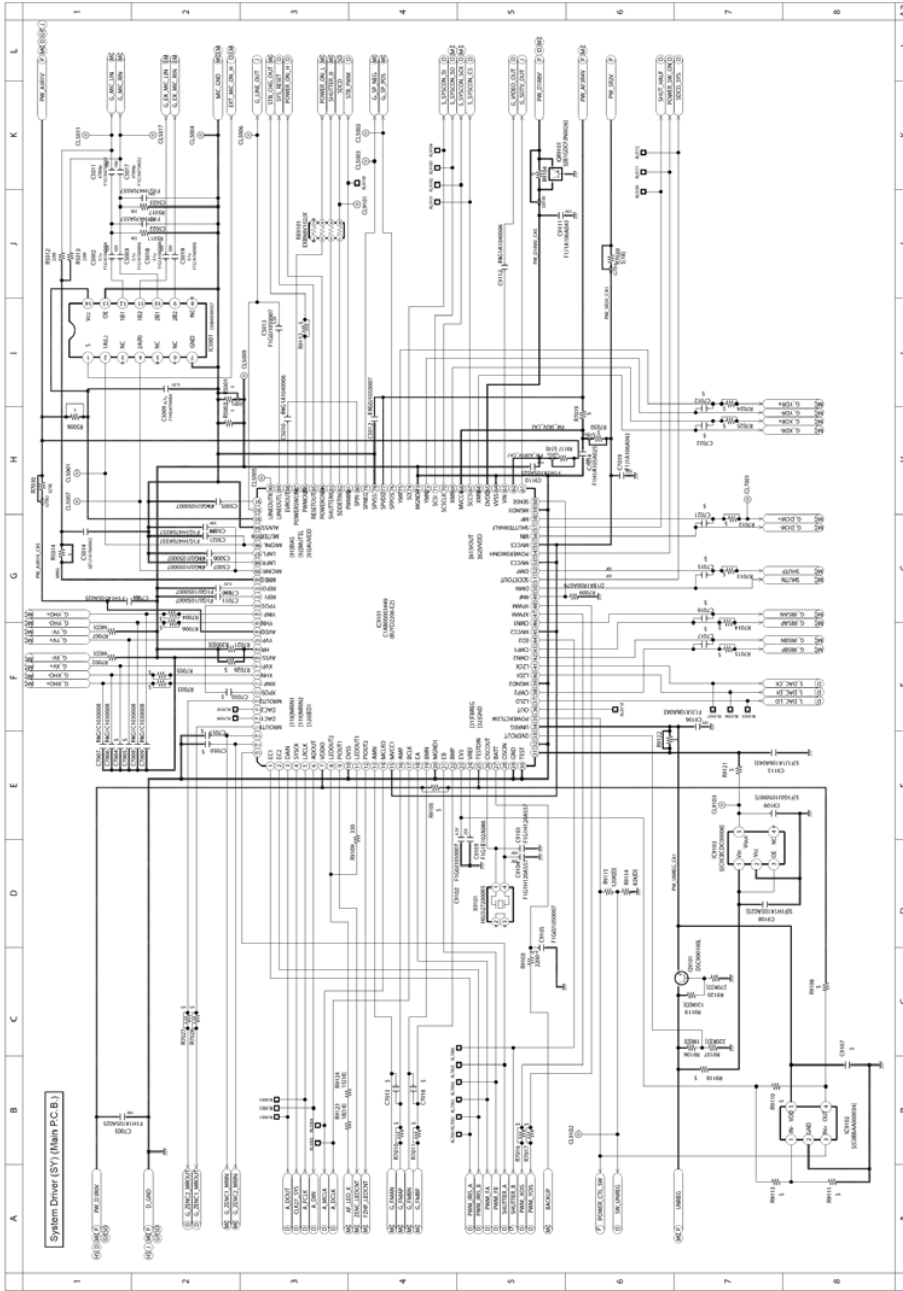

**Model No. : DMC-FZ200 Flash (Flash P.C.B.)**

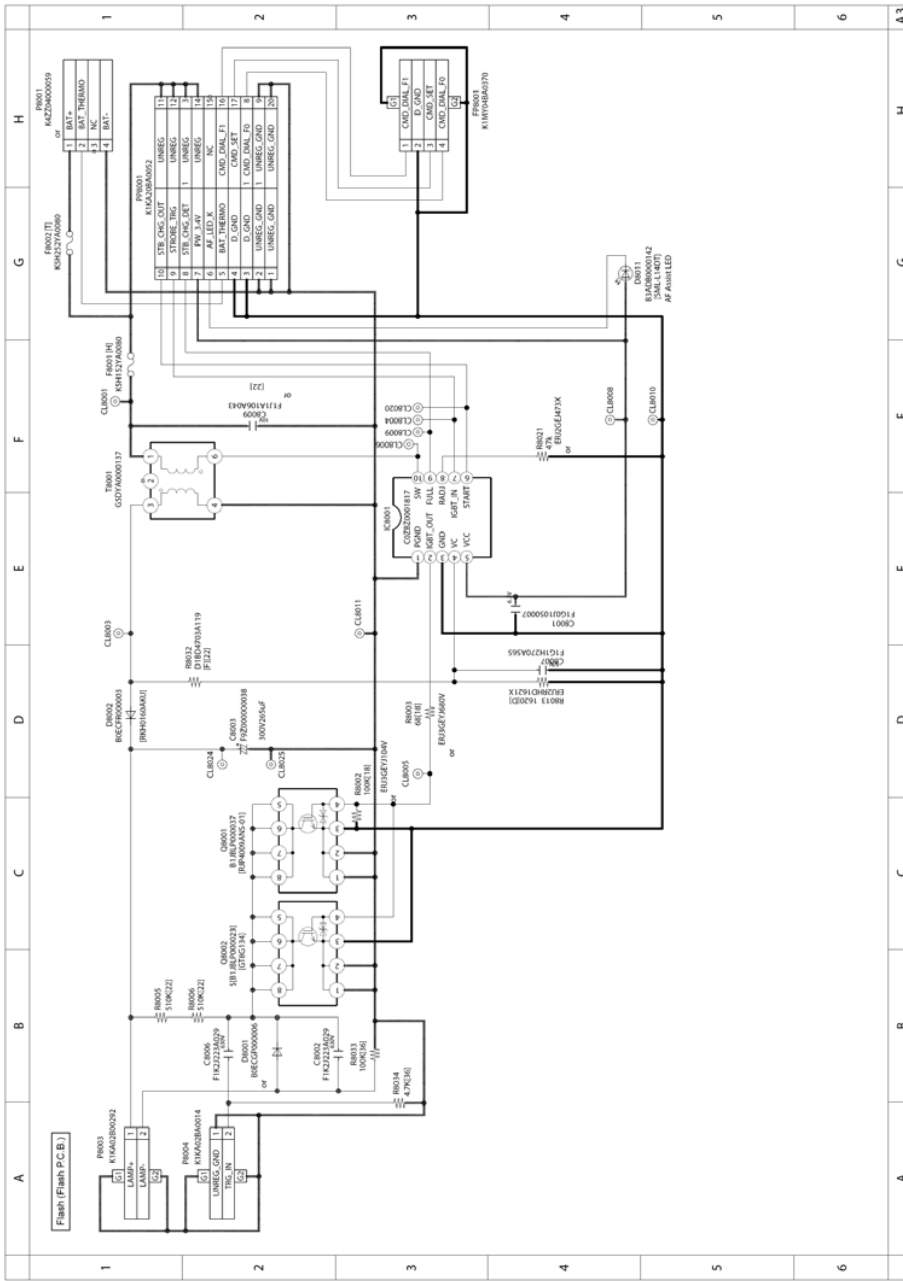

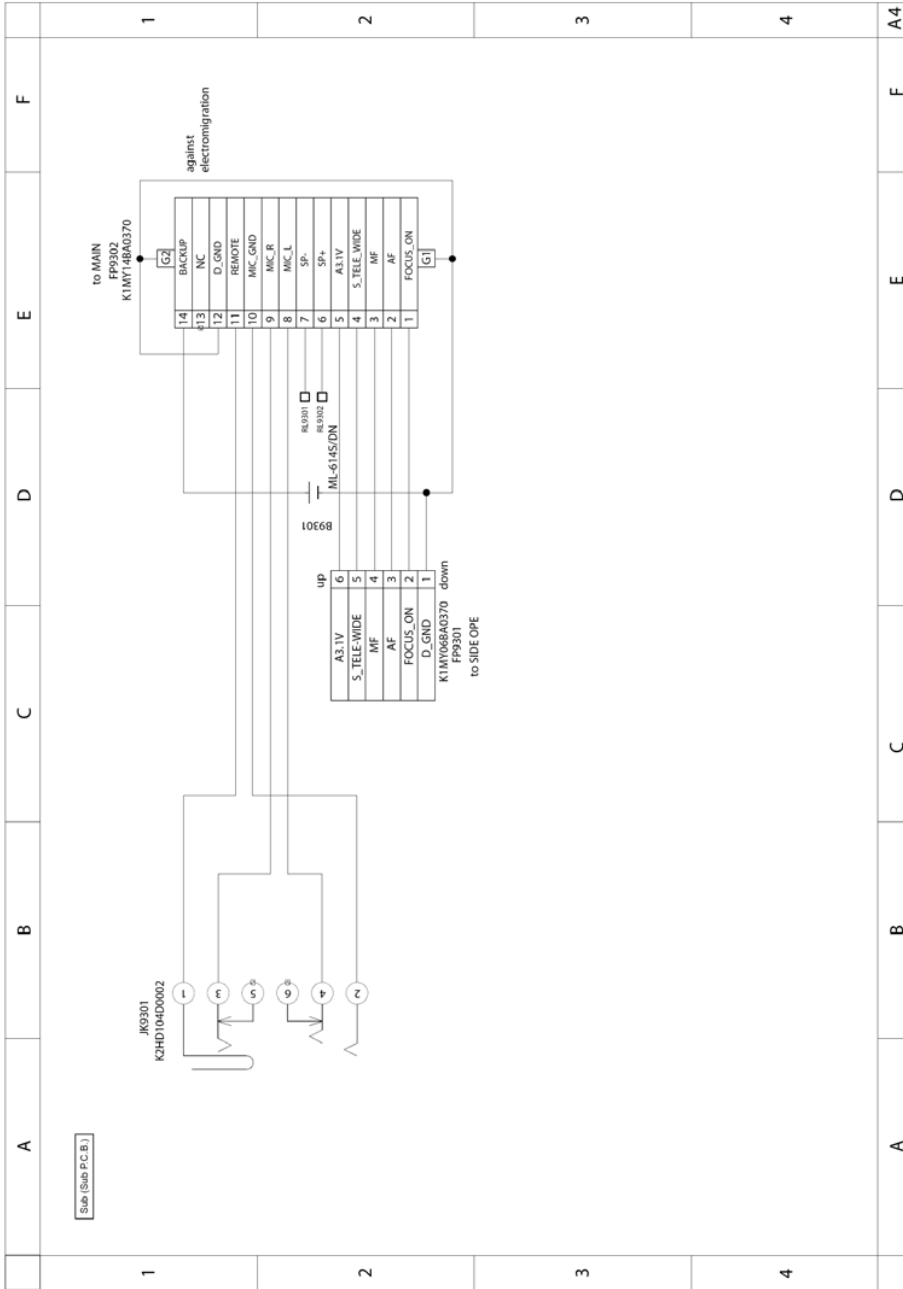

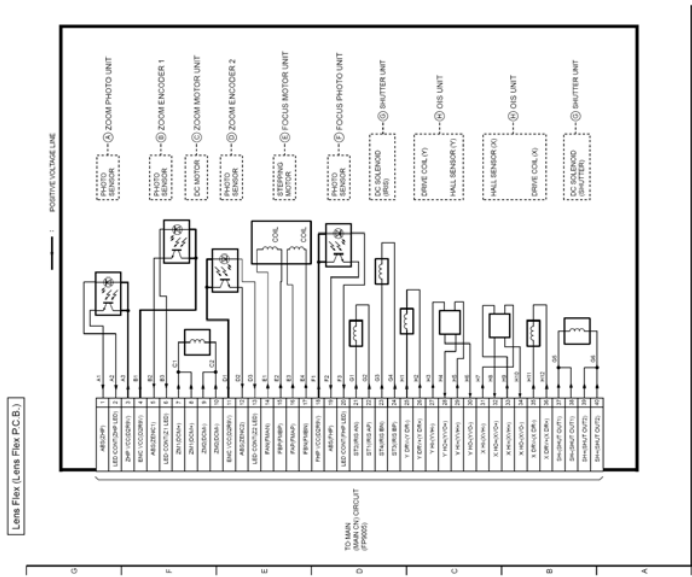

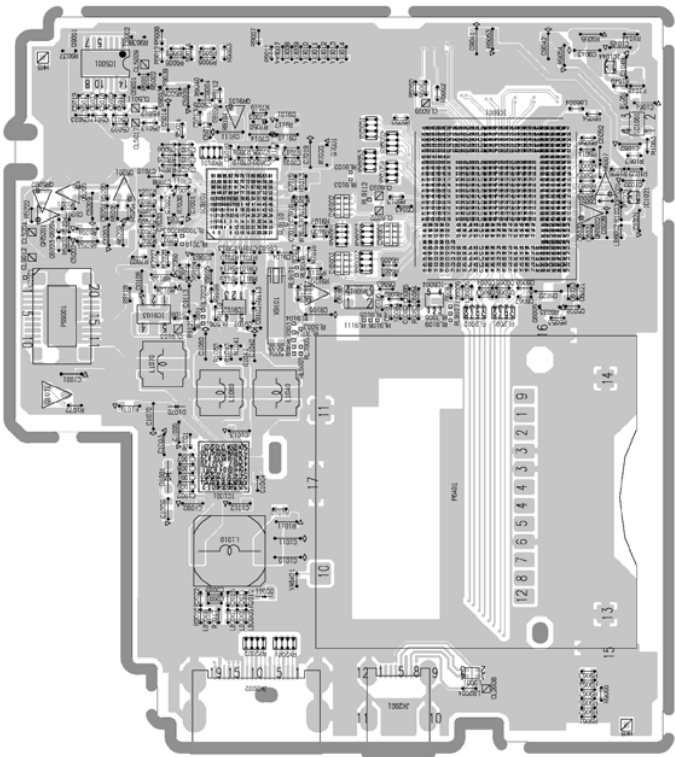



Model No. : DMC-FZ200 Main P.C.B. (Foil Side)

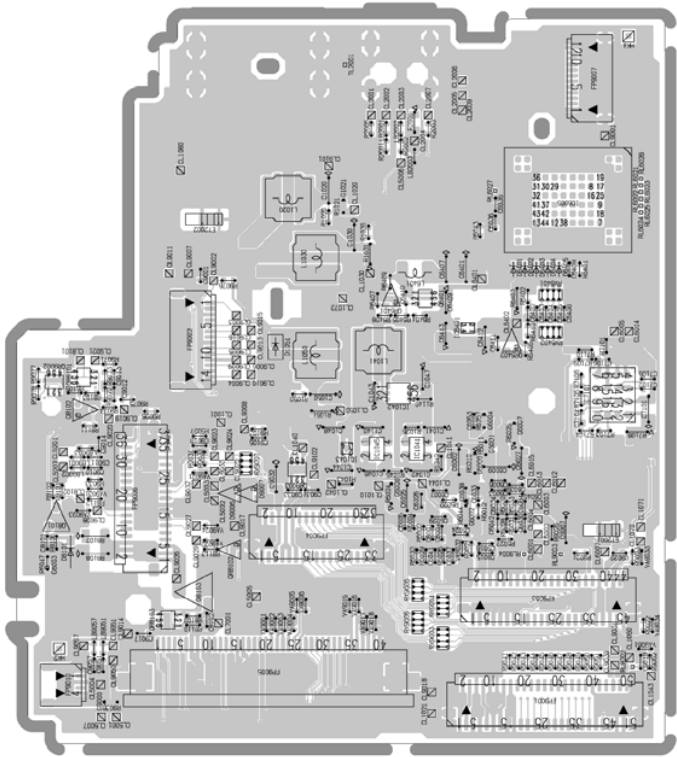

**Model No. : DMC-FZ200 Flash P.C.B. (Component Side)**

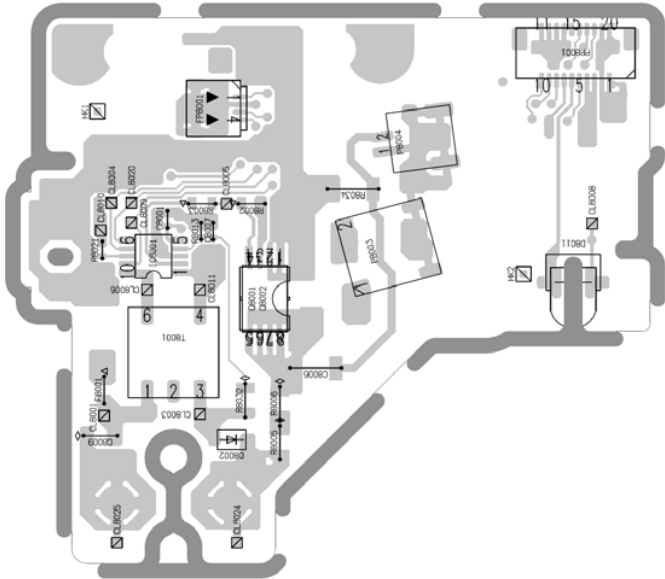

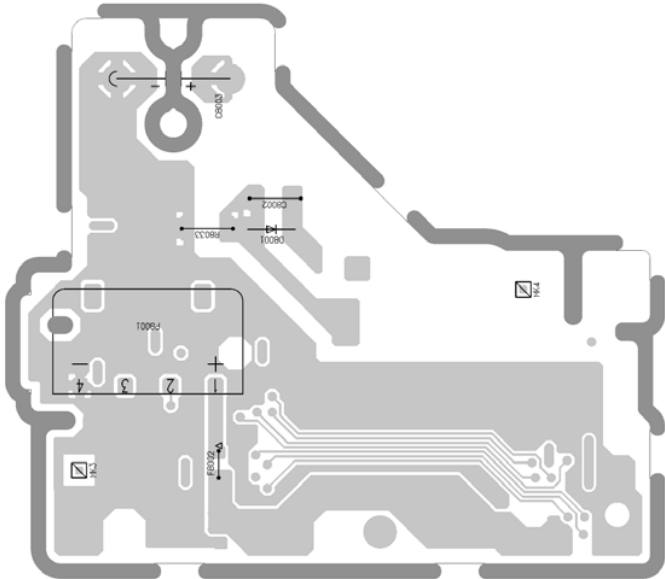

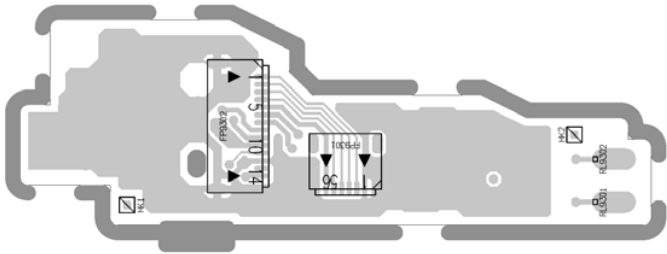

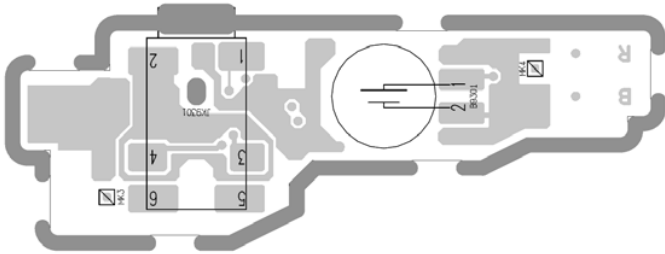

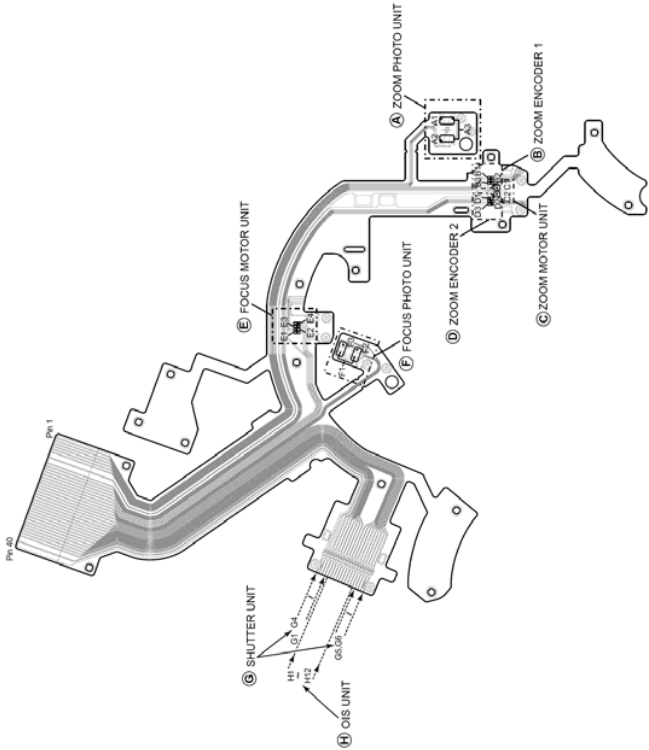

## Model No. : DMC-FZ200 Parts List

Change	Safety	Ref. No.	Part No.	Part Name & Description	Q'ty	Remarks
		C1001	F1H1A4750004	C.CAPACITOR CH 10V 4.7U	1	
		C1002	F1G1A1040006	C.CAPACITOR CH 10V 0.1U	1	
		C1003	F1H1A4750004	C.CAPACITOR CH 10V 4.7U	1	
		C1004	F1G0J1050007	C.CAPACITOR CH 6.3V 1U	1	
		C1005	F1H1A4750004	C.CAPACITOR CH 10V 4.7U	1	
		C1006	F1G0J1050007	C.CAPACITOR CH 6.3V 1U	1	
		C1007	F1G0J1050007	C.CAPACITOR CH 6.3V 1U	1	
		C1008	F1G0J1050007	C.CAPACITOR CH 6.3V 1U	1	
		C1009	ECJ1VB1A105K	C.CAPACITOR CH 10V 1U	1	
		C1010	FLJ0J2260004	C.CAPACITOR CH 6.3V 22U	1	
		C1011	FLJ1A106A043	C.CAPACITOR CH 10V 10U	1	
		C1012	F1H1A4750004	C.CAPACITOR CH 10V 4.7U	1	
		C1013	F1H1A4750004	C.CAPACITOR CH 10V 4.7U	1	
		C1020	FLJ1A106A043	C.CAPACITOR CH 10V 10U	1	
		C1021	ECJ1VB1A105K	C.CAPACITOR CH 10V 1U	1	
		C1022	ECJ1VB1A105K	C.CAPACITOR CH 10V 1U	1	
		C1030	FLJ1A106A043	C.CAPACITOR CH 10V 10U	1	
		C1040	FLJ0J2260004	C.CAPACITOR CH 6.3V 22U	1	
		C1041	ECJ1VB1A105K	C.CAPACITOR CH 10V 1U	1	
		C1042	ECJ1VB1A105K	C.CAPACITOR CH 10V 1U	1	
		C1043	ECJ1VB1A105K	C.CAPACITOR CH 10V 1U	1	
		C1044	ECJ1VB1A105K	C.CAPACITOR CH 10V 1U	1	
		C1045	ECJ1VB1A105K	C.CAPACITOR CH 10V 1U	1	
		C1046	ECJ1VB1A105K	C.CAPACITOR CH 10V 1U	1	
		C1047	ECJ1VB1A105K	C.CAPACITOR CH 10V 1U	1	
		C1048	ECJ1VB1A105K	C.CAPACITOR CH 10V 1U	1	
		C1049	ECJ1VB1A105K	C.CAPACITOR CH 10V 1U	1	
		C1050	FLJ0J2260004	C.CAPACITOR CH 6.3V 22U	1	
		C1060	FLJ1A106A043	C.CAPACITOR CH 10V 10U	1	
		C1061	ECJ1VB1A105K	C.CAPACITOR CH 10V 1U	1	
		C1062	ECJ1VB1A105K	C.CAPACITOR CH 10V 1U	1	
		C1070	FLJ1V1050001	C.CAPACITOR CH 35V 1U	1	
		C1091	F1G0J1050007	C.CAPACITOR CH 6.3V 1U	1	
		C1092	F1H1A4750004	C.CAPACITOR CH 10V 4.7U	1	
		C1140	ECJ1VB1A105K	C.CAPACITOR CH 10V 1U	1	
		C2001	F1G1A1040006	C.CAPACITOR CH 10V 0.1U	1	
		C2002	F1G0J1050007	C.CAPACITOR CH 6.3V 1U	1	
		C5002	F1G1A1040006	C.CAPACITOR CH 10V 0.1U	1	
		C5003	F1G1A1040006	C.CAPACITOR CH 10V 0.1U	1	
		C5005	F1G0J1050007	C.CAPACITOR CH 6.3V 1U	1	
		C5006	F1G0J1050007	C.CAPACITOR CH 6.3V 1U	1	
		C5007	F1G0J1050007	C.CAPACITOR CH 6.3V 1U	1	
		C5009	F1H0J4750004	C.CAPACITOR CH 6.3V 4.7U	1	
		C5010	F1G1A1040006	C.CAPACITOR CH 10V 0.1U	1	
		C5011	F1G1A473A032	C.CAPACITOR CH 10V 0.047U	1	
		C5012	F1G0J1050007	C.CAPACITOR CH 6.3V 1U	1	
		C5013	F1G0J1050007	C.CAPACITOR CH 6.3V 1U	1	
		C5017	F1G1A473A032	C.CAPACITOR CH 10V 0.047U	1	
		C5018	F1G1A1040006	C.CAPACITOR CH 10V 0.1U	1	
		C5019	F1G1A1040006	C.CAPACITOR CH 10V 0.1U	1	
		C5020	F1G1H470A557	C.CAPACITOR CH 50V 47P	1	
		C5021	F1G1H470A557	C.CAPACITOR CH 50V 47P	1	
		C5022	F1G1H4710004	C.CAPACITOR CH 50V 470P	1	
		C5023	F1G1H4710004	C.CAPACITOR CH 50V 470P	1	
		C5201	F1G1E472A086	C.CAPACITOR CH 25V 4700P	1	
		C5202	F1G1E472A086	C.CAPACITOR CH 25V 4700P	1	
		C5203	F1H0J4750004	C.CAPACITOR CH 6.3V 4.7U	1	
		C5204	F1G0J1050007	C.CAPACITOR CH 6.3V 1U	1	
		C5209	FLJ0J2260004	C.CAPACITOR CH 6.3V 22U	1	
		C6001	F1G0J1050007	C.CAPACITOR CH 6.3V 1U	1	
		C6002	FLJ1A106A043	C.CAPACITOR CH 10V 10U	1	
		C6003	F1G1A1040006	C.CAPACITOR CH 10V 0.1U	1	

## Model No. : DMC-FZ200 Parts List

Change	Safety	Ref. No.	Part No.	Part Name & Description	Q'ty	Remarks
		C6004	FIG1A1040006	C.CAPACITOR CH 10V 0.1U	1	
		C6005	FIG1A1040006	C.CAPACITOR CH 10V 0.1U	1	
		C6006	FIG1C1030008	C.CAPACITOR CH 16V 0.01U	1	
		C6007	FIG1C1030008	C.CAPACITOR CH 16V 0.01U	1	
		C6008	FIG1C1030008	C.CAPACITOR CH 16V 0.01U	1	
		C6009	FIG1A106A043	C.CAPACITOR CH 10V 10U	1	
		C6021	FIG1A1040006	C.CAPACITOR CH 10V 0.1U	1	
		C6022	FIG1A106A043	C.CAPACITOR CH 10V 10U	1	
		C6023	FIG1C1030008	C.CAPACITOR CH 16V 0.01U	1	
		C6025	FIG1A106A043	C.CAPACITOR CH 10V 10U	1	
		C6026	FIG1C1030008	C.CAPACITOR CH 16V 0.01U	1	
		C6027	FIG1A106A043	C.CAPACITOR CH 10V 10U	1	
		C6028	FIG1A106A043	C.CAPACITOR CH 10V 10U	1	
		C6029	FIG1C1030008	C.CAPACITOR CH 16V 0.01U	1	
		C6030	FIG1A1040006	C.CAPACITOR CH 10V 0.1U	1	
		C6031	FIG1A1040006	C.CAPACITOR CH 10V 0.1U	1	
		C6032	FIG1H3310003	C.CAPACITOR CH 50V 330P	1	
		C6033	FIG1A1040006	C.CAPACITOR CH 10V 0.1U	1	
		C6034	FIG1A1040006	C.CAPACITOR CH 10V 0.1U	1	
		C6035	FIG1C1030008	C.CAPACITOR CH 16V 0.01U	1	
		C6036	FIG1A1040006	C.CAPACITOR CH 10V 0.1U	1	
		C6037	FIG1A1040006	C.CAPACITOR CH 10V 0.1U	1	
		C6038	FIG1C1030008	C.CAPACITOR CH 16V 0.01U	1	
		C6040	FIG1C1030008	C.CAPACITOR CH 16V 0.01U	1	
		C6041	FIG1A1040006	C.CAPACITOR CH 10V 0.1U	1	
		C6042	FIG1A1040006	C.CAPACITOR CH 10V 0.1U	1	
		C6051	FIG0J1050007	C.CAPACITOR CH 6.3V 1U	1	
		C6052	FIG1A1040006	C.CAPACITOR CH 10V 0.1U	1	
		C6053	FIG1C1030008	C.CAPACITOR CH 16V 0.01U	1	
		C6081	FIG1A1040006	C.CAPACITOR CH 10V 0.1U	1	
		C6084	FIG1A1040006	C.CAPACITOR CH 10V 0.1U	1	
		C6085	FIG1C1030008	C.CAPACITOR CH 16V 0.01U	1	
		C6086	FIG1A1040006	C.CAPACITOR CH 10V 0.1U	1	
		C6401	FIG0J2260004	C.CAPACITOR CH 6.3V 22U	1	
		C6402	FIG1H100A723	C.CAPACITOR CH 50V 10P	1	
		C6403	FIG1H100A723	C.CAPACITOR CH 50V 10P	1	
		C6404	FIG1H100A723	C.CAPACITOR CH 50V 10P	1	
		C6405	FIG1H100A723	C.CAPACITOR CH 50V 10P	1	
		C6406	FIG1H100A723	C.CAPACITOR CH 50V 10P	1	
		C6407	FIG1A106A043	C.CAPACITOR CH 10V 10U	1	
		C6409	FIG0J4750004	C.CAPACITOR CH 6.3V 4.7U	1	
		C6410	FIG1C1030008	C.CAPACITOR CH 16V 0.01U	1	
		C6412	ECJ1VB1A105K	C.CAPACITOR CH 10V 1U	1	
		C6413	ECJ1VB1A105K	C.CAPACITOR CH 10V 1U	1	
		C7001	ECJ1VB1A105K	C.CAPACITOR CH 10V 1U	1	
		C7003	ECJ1VB1A105K	C.CAPACITOR CH 10V 1U	1	
		C7006	FIG1C1030008	C.CAPACITOR CH 16V 0.01U	1	
		C7007	FIG1C1030008	C.CAPACITOR CH 16V 0.01U	1	
		C7008	FIG1C1030008	C.CAPACITOR CH 16V 0.01U	1	
		C7009	FIG1C1030008	C.CAPACITOR CH 16V 0.01U	1	
		C7010	FIG0J1050007	C.CAPACITOR CH 6.3V 1U	1	
		C7011	FIG0J1050007	C.CAPACITOR CH 6.3V 1U	1	
		C7014	ECJ1VB1A105K	C.CAPACITOR CH 10V 1U	1	
		C7019	FIG1A106A043	C.CAPACITOR CH 10V 10U	1	
		C7101	FIG1A106A043	C.CAPACITOR CH 10V 10U	1	
		C7102	FIG1A1040006	C.CAPACITOR CH 10V 0.1U	1	
		C7104	FIG1A1040006	C.CAPACITOR CH 10V 0.1U	1	
		C7105	FIG1A1040006	C.CAPACITOR CH 10V 0.1U	1	
		C7106	FIG1A1040006	C.CAPACITOR CH 10V 0.1U	1	
		C8001	FIG0J1050007	C.CAPACITOR CH 6.3V 1U	1	[PAVCX]
		C8002	FIG2J223A029	C.CAPACITOR 630V 0.022U	1	[PAVCX]
		C8006	FIG2J223A029	C.CAPACITOR 630V 0.022U	1	[PAVCX]



## Model No. : DMC-FZ200 Parts List

Change	Safety	Ref. No.	Part No.	Part Name & Description	Q'ty	Remarks
		C8007	F1G1H270A565	C.CAPACITOR CH 50V 27	1	[PAVCX]
		C8009	F1J1A106A043	C.CAPACITOR CH 10V 10U	1	[PAVCX]
		C8101	F1G1C1030008	C.CAPACITOR CH 16V 0.01U	1	
		C8102	F1G1H3320004	C.CAPACITOR CH 50V 3300P	1	
		C9012	F1G1A1040006	C.CAPACITOR CH 10V 0.1U	1	
		C9013	F1G1A1040006	C.CAPACITOR CH 10V 0.1U	1	
		C9015	F1G1C1030008	C.CAPACITOR CH 16V 0.01U	1	
		C9016	F1G1C1030008	C.CAPACITOR CH 16V 0.01U	1	
		C9018	F1G0J1050007	C.CAPACITOR CH 6.3V 1U	1	
		C9019	F1G1A1040006	C.CAPACITOR CH 10V 0.1U	1	
		C9022	F1G1A1040006	C.CAPACITOR CH 10V 0.1U	1	
		C9031	F1G1A1040006	C.CAPACITOR CH 10V 0.1U	1	
		C9032	F1J1A106A043	C.CAPACITOR CH 10V 10U	1	
		C9033	F1G1A1040006	C.CAPACITOR CH 10V 0.1U	1	
		C9041	F1J1A106A043	C.CAPACITOR CH 10V 10U	1	
		C9042	F1J1A106A043	C.CAPACITOR CH 10V 10U	1	
		C9043	F1J1A106A043	C.CAPACITOR CH 10V 10U	1	
		C9101	F1G1E102A086	C.CAPACITOR CH 25V 1000P	1	
		C9102	F1G0J1050007	C.CAPACITOR CH 6.3V 1U	1	
		C9103	F1G1H120A557	C.CAPACITOR CH 50V 12P	1	
		C9104	F1G1H120A557	C.CAPACITOR CH 50V 12P	1	
		C9105	F1G0J1050007	C.CAPACITOR CH 6.3V 1U	1	
		C9106	F1J1A106A043	C.CAPACITOR CH 10V 10U	1	
		C9110	ECJ1VB1A105K	C.CAPACITOR CH 10V 1U	1	
		C9111	F1J1A106A043	C.CAPACITOR CH 10V 10U	1	
		C9112	F1G1A1040006	C.CAPACITOR CH 10V 0.1U	1	
		CX6001	F5A84103A020	CAPACITOR NETWORKS	1	
		CX6002	F5A84103A020	CAPACITOR NETWORKS	1	
		CX6003	F5A84103A020	CAPACITOR NETWORKS	1	
		D1001	B0JCGD000016	DIODE	1	E.S.D.
		D1051	B0JCMD000066	DIODE	1	E.S.D.
		D1070	B0JCF0000003	DIODE	1	E.S.D.
		D2001	DB2S31100L	DIODE	1	E.S.D.
		D8001	B0ECGP000006	DIODE	1	[PAVCX]E.S.D.
		D8002	B0ECFR000003	DIODE	1	[PAVCX]E.S.D.
		D8011	B3ADB0000142	DIODE	1	[PAVCX]E.S.D.
		D8101	DZ2J082M0L	DIODE	1	E.S.D.
		D8103	B2ABAP000006	DIODE	1	E.S.D.
		ET2001	K4ZZ01000208	EARTH TERMINAL	1	
		ET2002	K4ZZ01000208	EARTH TERMINAL	1	
	⚠	F1071	K5H1512A0024	FUSE 50V 0.15A	1	
	⚠	F2001	K5H1522A0018	FUSE 32V 1.5A	1	
	⚠	F8001	K5H152YA0080	FUSE 32V 2.0A	1	[PAVCX]
	⚠	F8002	K5H252YA0080	FUSE 32V 2.5A	1	[PAVCX]
		FL2001	EXC28CH900U	FILTER	1	
		FL2002	EXC28CH900U	FILTER	1	
		FP8001	K1MY04BA0370	CONNECTOR 4P	1	[PAVCX]
		FP9001	K1MY51BA0235	CONNECTOR 51P	1	
		FP9002	K1MY14BA0370	CONNECTOR 14P	1	
		FP9003	K1MY45BA0575	CONNECTOR 45P	1	
		FP9004	K1MY33BA0235	CONNECTOR 33P	1	
		FP9005	K1MN40BA0153	CONNECTOR 40P	1	
		FP9006	K1MY37BA0575	CONNECTOR 37P	1	
		FP9007	K1MY12BA0370	CONNECTOR 12P	1	
		FP9010	K1MY04BA0370	CONNECTOR 4P	1	
		FP9301	K1MY06BA0370	CONNECTOR 6P	1	[PAVCX]
		FP9302	K1MY14BA0370	CONNECTOR 14P	1	[PAVCX]
		IC1001	C1ZBZ0004634	IC	1	E.S.D.
		IC1021	C0DBGYY02517	IC	1	E.S.D.
		IC1041	C0DBGYY02148	IC	1	E.S.D.
		IC1042	C0DBAYY01175	IC	1	E.S.D.
		IC1043	C0DBGYY02497	IC	1	E.S.D.

## Model No. : DMC-FZ200 Parts List

Change	Safety	Ref. No.	Part No.	Part Name & Description	Q'ty	Remarks
		IC1044	C0DBGYY02497	IC	1	E.S.D.
		IC1045	C0DBGYY02122	IC	1	E.S.D.
		IC1061	C0DBGYY03383	IC	1	E.S.D.
		IC5001	COJBAR000567	IC	1	E.S.D.
		IC6001	VSG1014	IC	1	E.S.D.
		IC6004	COJBAA000479	IC	1	E.S.D.
		IC6005	29LV8BFZ200	IC	1	E.S.D.
		IC6401	C0DBGYY00779	IC	1	E.S.D.
		IC7101	EWTS9PSX1A	IC	1	E.S.D.
		IC8001	COZB20001817	IC	1	[PAVCX]E.S.D.
		IC9101	CLAB00003449	IC	1	E.S.D.
		JK2001	K1FB108E0008	JACK, AV OUT/DIGITAL	1	
		JK2002	K1FALL19E0020	JACK, HDMI	1	
		JK9301	K2HD104D0002	JACK	1	[PAVCX]
		L1010	G1C4R3M00003	CHIP INDUCTOR 4.3UH	1	
		L1020	G1C100MA0461	CHIP INDUCTOR 10UH	1	
		L1030	G1C100MA0461	CHIP INDUCTOR 10UH	1	
		L1040	G1C100MA0461	CHIP INDUCTOR 10UH	1	
		L1041	G1C4R7MA0477	CHIP INDUCTOR 4.7UH	1	
		L1050	G1C100MA0461	CHIP INDUCTOR 10UH	1	
		L1060	G1C100MA0461	CHIP INDUCTOR 10UH	1	
		L1070	G1C330MA0477	CHIP INDUCTOR 33UH	1	
		L2001	J0ZZB0000142	FILTER	1	
		L6401	G1C1R0MA0172	CHIP INDUCTOR 1UH	1	
		LB2001	J0JCC0000415	FILTER	1	
		LB2002	J0JCC0000415	FILTER	1	
		LB2003	J0JCC0000415	FILTER	1	
		LB2004	J0JCC0000415	FILTER	1	
		LB2005	J0JBC0000107	FILTER	1	
		LB2006	J0JBC0000107	FILTER	1	
		LB2007	J0JBC0000107	FILTER	1	
		LB2008	J0JBC0000107	FILTER	1	
		LB6002	J0JYC0000046	FILTER	1	
		LB6004	DOYAR0000007	FILTER	1	
		LB9001	J0JCC0000415	FILTER	1	
		LB9002	J0JCC0000415	FILTER	1	
		LB9003	J0JCC0000415	FILTER	1	
		P6401	K1NA09E00153	SD CARD CONNECTOR	1	
		P8001	K4ZZ04000059	CONNECTOR 4P	1	[PAVCX]
		P8003	K1KA02B00292	CONNECTOR 2P	1	[PAVCX]
		P8004	K1KA02BA0014	CONNECTOR 2P	1	[PAVCX]
		PP8001	K1KA20BA0052	CONNECTOR 20P	1	[PAVCX]
		PS9001	K1KB20AA0094	CONNECTOR 20P	1	
		Q1071	FK3503010L	TRANSISTOR	1	E.S.D.
		Q5201	B1ABDF000017	TRANSISTOR	1	E.S.D.
		Q5206	B1ABDF000017	TRANSISTOR	1	E.S.D.
		Q6401	B1CHMB000007	TRANSISTOR	1	E.S.D.
		Q8001	B1JBLP000037	TRANSISTOR	1	[PAVCX]E.S.D.
		Q8101	B1CFHD000027	TRANSISTOR	1	E.S.D.
		Q8102	B1ABCF000103	TRANSISTOR	1	E.S.D.
		Q9101	DSC900100L	TRANSISTOR	1	E.S.D.
		QR5201	B1GDCFNN0031	TRANSISTOR-RESISTOR	1	E.S.D.
		QR5202	B1GBCFNL0020	TRANSISTOR-RESISTOR	1	E.S.D.
		QR6001	DRC3144W0L	TRANSISTOR-RESISTOR	1	E.S.D.
		QR6002	B1GBCFJN0041	TRANSISTOR-RESISTOR	1	E.S.D.
		QR6401	B1GBCFJJ0064	TRANSISTOR-RESISTOR	1	E.S.D.
		QR6402	B1GDCFGN0024	TRANSISTOR-RESISTOR	1	E.S.D.
		QR8101	B1GKCFGN0003	TRANSISTOR-RESISTOR	1	E.S.D.
		QR8102	B1GBCFJJ0064	TRANSISTOR-RESISTOR	1	E.S.D.
		QR8103	B1GKCFJN0003	TRANSISTOR-RESISTOR	1	E.S.D.
		QR9002	B1GFCFJJ0016	TRANSISTOR-RESISTOR	1	E.S.D.
		QR9003	B1GKCFGG0003	TRANSISTOR-RESISTOR	1	E.S.D.

## Model No. : DMC-FZ200 Parts List

Change	Safety	Ref. No.	Part No.	Part Name & Description	Q'ty	Remarks
		R1001	ERJ2RHD473	M.RESISTOR CH 1/16W 47K	1	
		R1072	ERJ2RKD120	M.RESISTOR CH 1/16W 12	1	
		R2001	ERJ2GEJ750	M.RESISTOR CH 1/10W 75	1	
		R2002	ERJ2GEJ561	M.RESISTOR CH 1/16W 560	1	
		R2003	ERJ2GEJ102Y	M.RESISTOR CH 1/10W 1K	1	
		R2005	ERJ2GEJ102Y	M.RESISTOR CH 1/10W 1K	1	
		R2011	ERJ2GEJ202	M.RESISTOR CH 1/10W 2K	1	
		R2012	ERJ2GED273X	M.RESISTOR CH 1/10W 27K	1	
		R2015	ERJ2GEJ202	M.RESISTOR CH 1/10W 2K	1	
		R2016	ERJ2RHD682X	M.RESISTOR CH 1/10W 6.8K	1	
		R2022	ERJ2GEJ103	M.RESISTOR CH 1/10W 10K	1	
		R5011	ERJ2GEJ333	M.RESISTOR CH 1/16W 33K	1	
		R5012	ERJ2GEJ222	M.RESISTOR CH 1/10W 2.2K	1	
		R5013	ERJ2GEJ222	M.RESISTOR CH 1/10W 2.2K	1	
		R5017	ERJ2GEJ333	M.RESISTOR CH 1/16W 33K	1	
		R5201	ERA3YED562V	M.RESISTOR CH 1/16W 5.6K	1	
		R5202	ERA3YED331	M.RESISTOR CH 1/16W 330	1	
		R5203	ERA3YED562V	M.RESISTOR CH 1/16W 5.6K	1	
		R5204	ERJ2GEJ473Y	M.RESISTOR CH 1/10W 47K	1	
		R5205	ERJ2GEJ683	M.RESISTOR CH 1/16W 68K	1	
		R5206	ERJ2GEJ223	M.RESISTOR CH 1/16W 22K	1	
		R5221	ERJ2GEJ472	M.RESISTOR CH 1/10W 4.7K	1	
		R6001	ERJ2RKF1183	M.RESISTOR CH 1/16W 118K	1	
		R6002	ERJ2RHD222	M.RESISTOR CH 1/16W 2.2K	1	
		R6004	ERJ2RHD122	M.RESISTOR CH 1/16W 1.2K	1	
		R6005	ERJ2RHD561	M.RESISTOR CH 1/16W 560	1	
		R6006	ERJ2GEJ472	M.RESISTOR CH 1/10W 4.7K	1	
		R6007	ERJ2GEJ472	M.RESISTOR CH 1/10W 4.7K	1	
		R6009	ERJ2GEJ102Y	M.RESISTOR CH 1/10W 1K	1	
		R6012	ERJ2RHD511	M.RESISTOR CH 1/16W 510	1	
		R6013	ERJ2GEJ101	M.RESISTOR CH 1/10W 100	1	
		R6022	ERJ2RKF6201	M.RESISTOR CH 1/16W 6.2K	1	
		R6026	ERJ2RHD241	M.RESISTOR CH 1/16W 240	1	
		R6027	ERJ2RKF2800	M.RESISTOR CH 1/16W 28	1	
		R6028	ERJ2RHD511	M.RESISTOR CH 1/16W 510	1	
		R6029	ERJ2RHD511	M.RESISTOR CH 1/16W 510	1	
		R6030	ERJ2RHD511	M.RESISTOR CH 1/16W 510	1	
		R6031	ERJ2RHD511	M.RESISTOR CH 1/16W 510	1	
		R6032	ERJ2RHD511	M.RESISTOR CH 1/16W 510	1	
		R6033	ERJ2RHD511	M.RESISTOR CH 1/16W 510	1	
		R6043	ERJ2GEJ103	M.RESISTOR CH 1/10W 10K	1	
		R6052	ERJ2GEJ470	M.RESISTOR CH 1/16W 47	1	
		R6053	ERJ2GEJ473Y	M.RESISTOR CH 1/10W 47K	1	
		R6054	ERJ2GEJ390	M.RESISTOR CH 1/16W 39	1	
		R6056	ERJ2RKD330	M.RESISTOR CH 1/16W 33	1	
		R6081	ERJ2GEJ101	M.RESISTOR CH 1/10W 100	1	
		R6082	ERJ2GEJ470	M.RESISTOR CH 1/16W 47	1	
		R6083	ERJ2GEJ472	M.RESISTOR CH 1/10W 4.7K	1	
		R6084	ERJ2GEJ472	M.RESISTOR CH 1/10W 4.7K	1	
		R6086	ERJ2GEJ102Y	M.RESISTOR CH 1/10W 1K	1	
		R6087	ERJ2GEJ102Y	M.RESISTOR CH 1/10W 1K	1	
		R6401	ERJ2GEJ102Y	M.RESISTOR CH 1/10W 1K	1	
		R6402	ERJ2GEJ223	M.RESISTOR CH 1/16W 22K	1	
		R6404	ERJ2GEJ104	M.RESISTOR CH 1/10W 100K	1	
		R6405	ERJ2GEJ103	M.RESISTOR CH 1/10W 10K	1	
		R6410	ERJ2GEJ680	M.RESISTOR CH 1/10W 68	1	
		R7002	ERJ2RKD680	M.RESISTOR CH 1/16W 68	1	
		R7007	ERJ2RKD680	M.RESISTOR CH 1/16W 68	1	
		R7009	D1BA1R00A079	M.RESISTOR CH 1/8W 1	1	
		R7021	ERJ2RHD822X	M.RESISTOR CH 1/16W 8.2K	1	
		R8002	DOGB104JA065	M.RESISTOR CH 1/10W 100K	1	[PAVCX]
		R8003	DOGB680JA065	CHIP RESISTOR	1	[PAVCX]

## Model No. : DMC-FZ200 Parts List

Change	Safety	Ref. No.	Part No.	Part Name & Description	Q'ty	Remarks
		R8005	ERJ6GEYJ514V	M.RESISTOR CH 1/8W 510K	1	[PAVCX]
		R8006	ERJ6GEYJ514V	M.RESISTOR CH 1/8W 510K	1	[PAVCX]
		R8013	ERJ2RHD1621X	M.RESISTOR CH 1/16W 1620	1	[PAVCX]
		R8021	DOGA473JA023	CHIP RESISTOR	1	[PAVCX]
		R8032	D1BD4703A119	CHIP RESISTOR	1	[PAVCX]
		R8033	ERJ8GEYJ104V	M.RESISTOR CH 1/4W 100K	1	[PAVCX]
		R8034	ERJ8GEYJ472V	M.RESISTOR CH 1/4W 4.7K	1	[PAVCX]
		R8101	ERJ2GEJ103	M.RESISTOR CH 1/10W 10K	1	
		R8103	ERJ2GEJ223	M.RESISTOR CH 1/16W 22K	1	
		R8105	ERJ2GEJ223	M.RESISTOR CH 1/16W 22K	1	
		R8107	ERJ6GEYJ106V	M.RESISTOR CH 1/10W 10M	1	
		R8108	ERJ6GEYJ106V	M.RESISTOR CH 1/10W 10M	1	
		R8109	ERJ2GEJ102Y	M.RESISTOR CH 1/10W 1K	1	
		R8110	ERJ2GEJ471	M.RESISTOR CH 1/10W 470	1	
		R8111	ERJ2GEJ331	M.RESISTOR CH 1/16W 330	1	
		R8112	ERJ2GEJ331	M.RESISTOR CH 1/16W 330	1	
		R8113	ERJ2GEJ331	M.RESISTOR CH 1/16W 330	1	
		R9003	ERJ2GEJ821	M.RESISTOR CH 1/10W 820	1	
		R9005	ERJ2GED563X	M.RESISTOR CH 1/10W 56K	1	
		R9006	ERJ2GED563X	M.RESISTOR CH 1/10W 56K	1	
		R9007	ERJ2GED273X	M.RESISTOR CH 1/10W 27K	1	
		R9008	ERJ2GED273X	M.RESISTOR CH 1/10W 27K	1	
		R9011	ERJ2GEJ221	M.RESISTOR CH 1/16W 220	1	
		R9012	ERJ2GEJ221	M.RESISTOR CH 1/16W 220	1	
		R9014	ERJ2GEJ821	M.RESISTOR CH 1/10W 820	1	
		R9021	ERJ2GEJ102Y	M.RESISTOR CH 1/10W 1K	1	
		R9022	ERJ2GEJ102Y	M.RESISTOR CH 1/10W 1K	1	
		R9023	ERJ2GEJ102Y	M.RESISTOR CH 1/10W 1K	1	
		R9024	ERJ2GEJ101	M.RESISTOR CH 1/10W 100	1	
		R9026	ERJ2GEJ101	M.RESISTOR CH 1/10W 100	1	
		R9033	ERJ2GEJ101	M.RESISTOR CH 1/10W 100	1	
		R9041	ERJ2RKF1000	M.RESISTOR CH 1/16W 1K	1	
		R9042	ERJ2RKF1000	M.RESISTOR CH 1/16W 1K	1	
		R9043	ERJ2RKF1000	M.RESISTOR CH 1/16W 1K	1	
		R9044	ERJ2RKF1000	M.RESISTOR CH 1/16W 1K	1	
		R9045	ERJ2RKF1000	M.RESISTOR CH 1/16W 1K	1	
		R9046	ERJ2RKF1000	M.RESISTOR CH 1/16W 1K	1	
		R9047	ERJ2RKF1000	M.RESISTOR CH 1/16W 1K	1	
		R9048	ERJ2RKF1000	M.RESISTOR CH 1/16W 1K	1	
		R9049	ERJ2RKF1000	M.RESISTOR CH 1/16W 1K	1	
		R9050	ERJ2RKF1000	M.RESISTOR CH 1/16W 1K	1	
		R9051	ERJ2RKF1000	M.RESISTOR CH 1/16W 1K	1	
		R9052	ERJ2GEJ102Y	M.RESISTOR CH 1/10W 1K	1	
		R9061	ERJ2GEJ242	M.RESISTOR CH 1/16W 2.4K	1	
		R9062	ERJ2GEJ392	M.RESISTOR CH 1/10W 3.9K	1	
		R9063	ERJ2GEJ242	M.RESISTOR CH 1/16W 2.4K	1	
		R9064	ERJ2GEJ392	M.RESISTOR CH 1/10W 3.9K	1	
		R9065	ERJ2GEJ242	M.RESISTOR CH 1/16W 2.4K	1	
		R9066	ERJ2GEJ392	M.RESISTOR CH 1/10W 3.9K	1	
		R9067	ERJ2GEJ752X	M.RESISTOR CH 1/10W 7.5K	1	
		R9071	ERJ2GEJ392	M.RESISTOR CH 1/10W 3.9K	1	
		R9072	ERJ2GEJ103	M.RESISTOR CH 1/10W 10K	1	
		R9073	ERJ2GEJ103	M.RESISTOR CH 1/10W 10K	1	
		R9074	ERJ2GEJ392	M.RESISTOR CH 1/10W 3.9K	1	
		R9075	ERJ2GEJ102Y	M.RESISTOR CH 1/10W 1K	1	
		R9076	ERJ2GEJ201	M.RESISTOR CH 1/16W 200	1	
		R9077	ERJ2GEJ152	M.RESISTOR CH 1/16W 1.5K	1	
		R9078	ERJ2GEJ472	M.RESISTOR CH 1/10W 4.7K	1	
		R9103	ERJ2GEJ222	M.RESISTOR CH 1/10W 2.2K	1	
		R9106	ERJ2RKD105	M.RESISTOR CH 1/16W 1M	1	
		R9107	ERJ2RKD224	M.RESISTOR CH 1/16W 220K	1	
		R9109	ERJ2GEJ331	M.RESISTOR CH 1/16W 330	1	

## Model No. : DMC-FZ200 Parts List

Change	Safety	Ref. No.	Part No.	Part Name & Description	Q'ty	Remarks
		R9114	ERJ2RHD823	M.RESISTOR CH 1/16W 82K	1	
		R9115	ERJ2RKD124	M.RESISTOR CH 1/16W 120K	1	
		R9119	ERJ2RKD124	M.RESISTOR CH 1/16W 120K	1	
		R9120	ERJ2RKD274	M.RESISTOR CH 1/16W 270K	1	
		R9123	DOGB180JA057	M.RESISTOR CH 1/10W 18	1	
		R9124	DOGB150JA057	M.RESISTOR CH 1/10W 15	1	
		RX6001	EXBN8V103J	RESISTOR NETWORKS	1	
		RX6002	EXBN8V101JX	RESISTOR NETWORKS	1	
		RX6003	EXBN8V103J	RESISTOR NETWORKS	1	
		RX6051	EXBN8V101JX	RESISTOR NETWORKS	1	
		RX6052	EXBN8V101JX	RESISTOR NETWORKS	1	
		RX6053	EXBN8V101JX	RESISTOR NETWORKS	1	
		RX6054	EXBN8V101JX	RESISTOR NETWORKS	1	
		RX6401	EXBN8V473J	RESISTOR NETWORKS	1	
		RX6402	EXBN8V680J	RESISTOR NETWORKS	1	
		RX9003	EXBN8V101JX	RESISTOR NETWORKS	1	
		RX9004	EXBN8V101JX	RESISTOR NETWORKS	1	
		RX9005	EXBN8V101JX	RESISTOR NETWORKS	1	
		RX9006	EXBN8V101JX	RESISTOR NETWORKS	1	
		RX9007	EXBN8V101JX	RESISTOR NETWORKS	1	
		RX9101	EXBN8V102J	RESISTOR NETWORKS	1	
		T8001	G5DYA0000137	TRANSFORMER	1	[ PAVCX ]
		VA9021	D4ED18R00008	VARISTOR	1	
		X6081	H4Z7205B0001	CRYSTAL OSCILLATOR	1	
		X9101	H0J327200085	CRYSTAL OSCILLATOR	1	

**Model No. : DMC-FZ200 Frame and Casing Section**

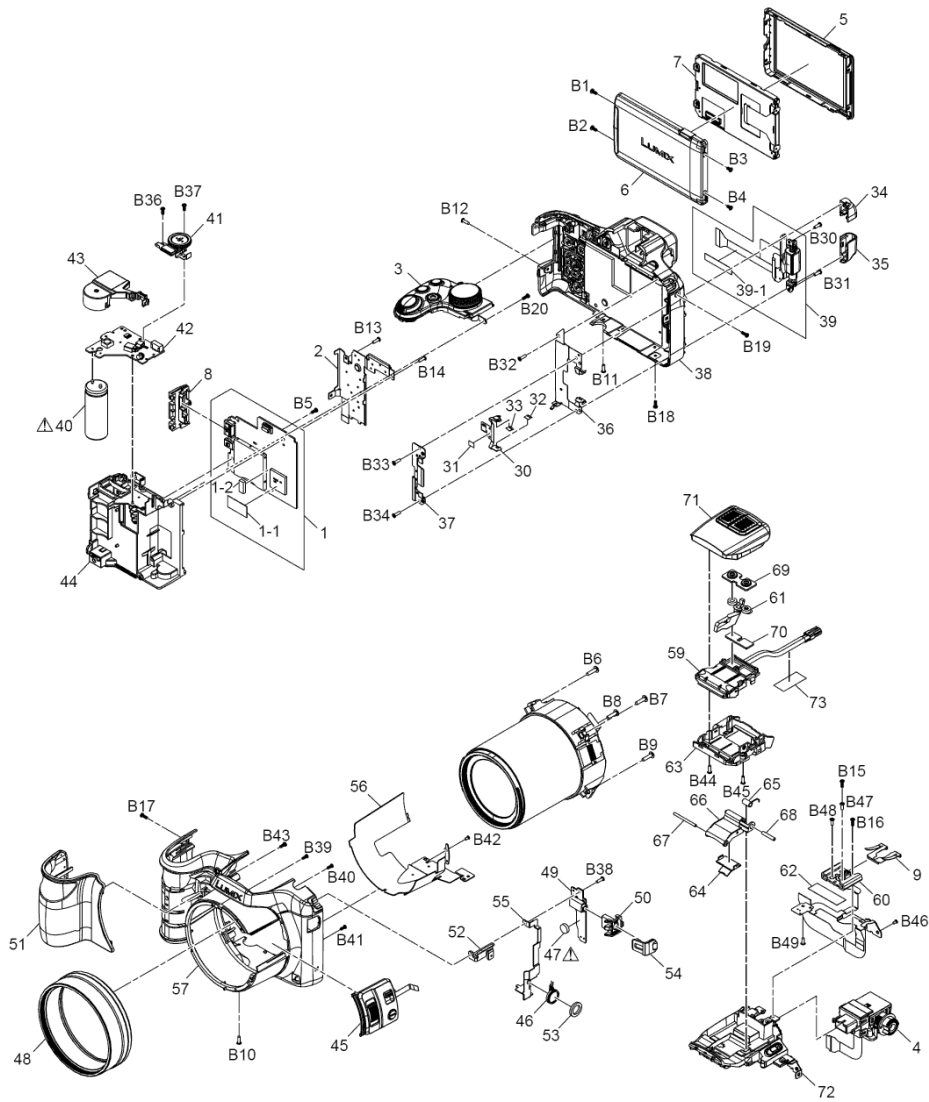

**Model No. : DMC-FZ200 Camera Lens Section**

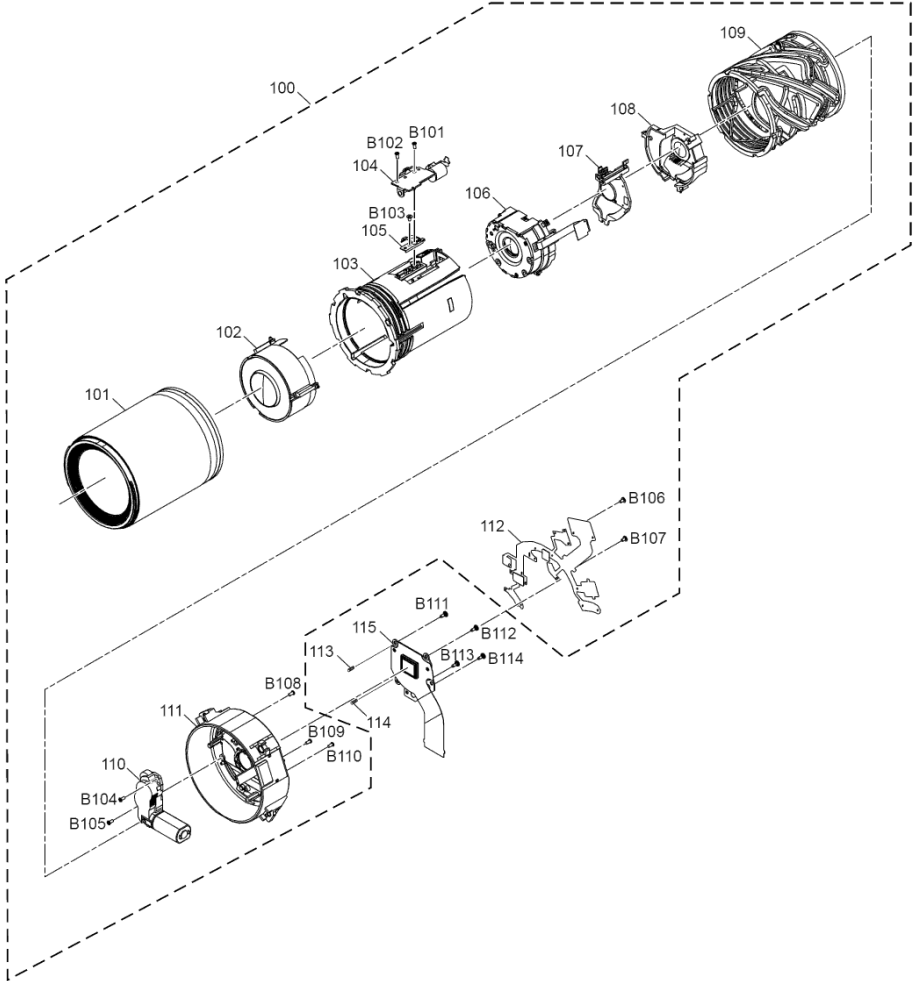

**Model No. : DMC-FZ200 Packing Parts and Accessories Section**

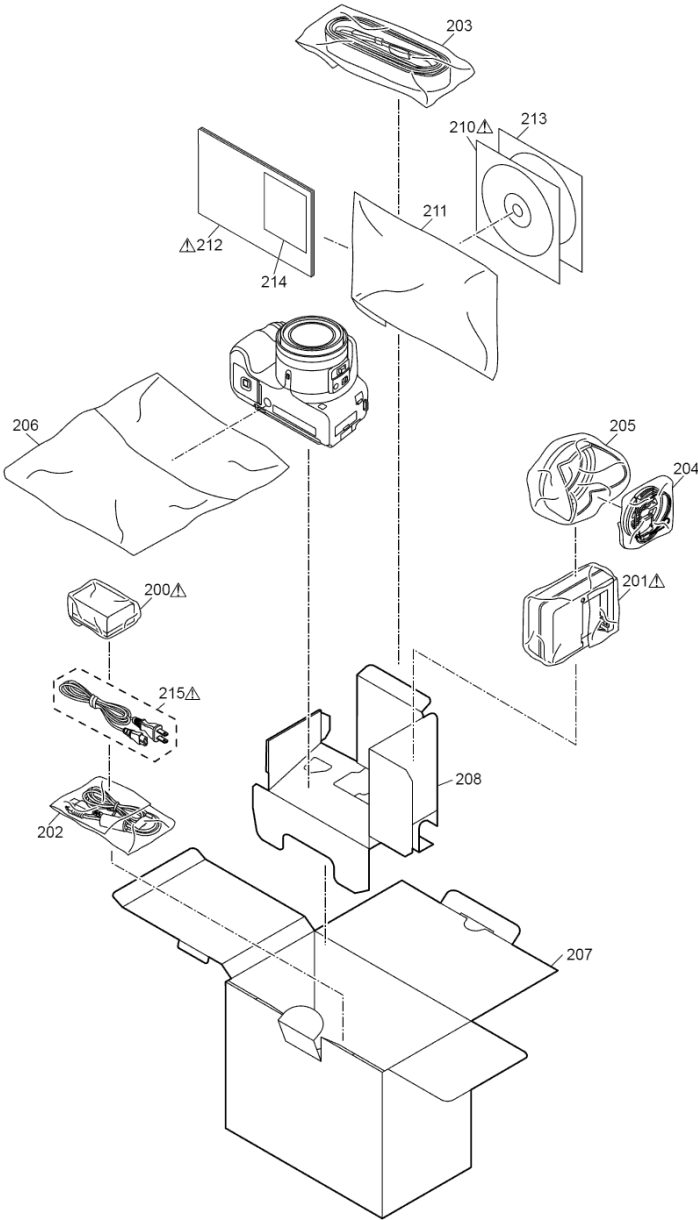



## Model No. : DMC-FZ200 Parts List

Change	Safety	Ref. No.	Part No.	Part Name & Description	Q'ty	Remarks
		1	VEP56170A	MAIN P.C.B.	1	(RTL) E.S.D. P,PC,PU,EE,GC,SG,GT,GK,GN
		1	VEP56170B	MAIN P.C.B.	1	(RTL) E.S.D. EG,EP,EF,EB
		1-1	VGQ1H72	MAIN COPPER SHEET	1	
		1-2	VGQ1H73	HEAT RADIATION SHEET	1	
		2	KORB01000015	REAR OPERATION UNIT	1	
		3	KORB01700001	TOP OPERATION UNIT	1	
		4	L5EDDY00421	EVF UNIT	1	
		5	VKM9529	LCD CASE (TOP)	1	
		6	VKM0B72	LCD CASE (BOTTOM)	1	
		7	VYK5G58	LCD UNIT	1	
		8	VGQ1E10	JACK HOLDER	1	
		9	VMC2111	SHOE SPRING	1	
		30	VEP59105A	HINGE SW FPC	1	[PAVCX]
		31	VGQ0V71	HINGE SW FPC SHEET	1	[PAVCX]
		32	VGQ0Y75	HINGE SW TAPE	1	[PAVCX]
		33	VGQ0Y75	HINGE SW TAPE	1	[PAVCX]
		34	VKM0B75	HINGE ARM COVER TOP	1	[PAVCX]
		35	VKM0B76	HINGE ARM COVER BOTTOM	1	[PAVCX]
		36	VMC2217	REAR EARTH PLATE B	1	[PAVCX]
		37	VMP0A09	HINGE PLATE	1	[PAVCX]
		38	VYK5V56	REAR CASE UNIT	1	[PAVCX]
		39	VYK5W48	LCD HINGE UNIT	1	[PAVCX]
		39-1	VGQ1H74	DPR SHEET	1	[PAVCX]
	⚠	40	F9Z000000038	E.CAPACITOR	1	[PAVCX](C8003)
		41	KORB00300004	SWITCH UNIT	1	[PAVCX]
		42	VEP58183A	FLASH P.C.B.	1	[PAVCX](RTL) E.S.D.
		43	VGQ1D82	CONDENSOR COVER	1	[PAVCX]
		44	VYK5V61	BATTERY CASE UNIT	1	[PAVCX]
		45	KORB00300003	SIDE SWITCH UNIT	1	[PAVCX]
		46	LOAA01A00100	SPEAKER	1	[PAVCX]
	⚠	47	ML-614S/DN	BUTTON BATTERY	1	[ENERGY] (B9301)
		48	VDW2491	LENS RING FRONT	1	[PAVCX]
		49	VEP59120A	SUB P.C.B.	1	[PAVCX](RTL)
		50	VGQ0W52	REMOTE HOLDER	1	[PAVCX]
		51	VGQ1D75	GRIP PIECE FRONT	1	[PAVCX]
		52	VGQ1D78	STRAP HOLDER (R)	1	[PAVCX]
		53	VGQ1H40	SP SPACER A	1	[PAVCX]
		54	VKF5073	REMOTE COVER	1	[PAVCX]
		55	VMP0C97	SIDE FRAME (R)	1	[PAVCX]
		56	VSC6424	FRONT HEAT SINK	1	[PAVCX]
		57	VYK5V53	FRONT CASE UNIT	1	[PAVCX]
		59	EFN-AMDK7ZJ	FLASH	1	[PAVCX]
		60	VEK0T25	HOT SHOE UNIT	1	[PAVCX]
		61	VEP54034A	MIC FPC UNIT	1	[PAVCX]
		62	VGQ1F41	MULTI HOT SHOE FPC SHEET	1	[PAVCX]
		63	VKM0B70	FLASH CASE BOTTOM	1	[PAVCX]
		64	VKM0B74	FLASH LINK COVER	1	[PAVCX]
		65	VMB4614	FLASH SPRING	1	[PAVCX]
		66	VMM0479	FLASH LINK	1	[PAVCX]
		67	VMS8267	FLASH SHAFT	1	[PAVCX]
		68	VMS8286	FLASH SHAFT 2	1	[PAVCX]
		69	VMT1962	MIC DAMPER	1	[PAVCX]
		70	VMT2011	MIC CUSHION	1	[PAVCX]
		71	VYK5V58	FLASH CASE TOP UNIT	1	[PAVCX]
		72	VYK5Z73	FLASH BASE UNIT	1	[PAVCX]
		73	VGQ1H36	REED WIRE SHEET	1	[PAVCX]
		B1	VHD2149	SCREW	1	
		B2	VHD2149	SCREW	1	
		B3	VHD2179	SCREW	1	
		B4	VHD2179	SCREW	1	
		B5	XQN16+BJ4FN	SCREW	1	

## Model No. : DMC-FZ200 Parts List

Change	Safety	Ref. No.	Part No.	Part Name & Description	Q'ty	Remarks
		B6	XTV2+8JFN	SCREW	1	
		B7	XTV2+8JFN	SCREW	1	
		B8	XTV2+8JFN	SCREW	1	
		B9	XTV2+8JFN	SCREW	1	
		B10	VHD1870	SCREW	1	
		B11	VHD1870	SCREW	1	
		B12	VHD1870	SCREW	1	
		B13	VHD1870	SCREW	1	
		B14	VHD1870	SCREW	1	
		B15	VHD2337	SCREW	1	
		B16	VHD2337	SCREW	1	
		B17	VHD2337	SCREW	1	
		B18	VHD2337	SCREW	1	
		B19	VHD2337	SCREW	1	
		B20	VHD2337	SCREW	1	
		B30	VHD2190	SCREW	1	[ PAVCX ]
		B31	VHD2190	SCREW	1	[ PAVCX ]
		B32	VHD2281	SCREW	1	[ PAVCX ]
		B33	VHD2281	SCREW	1	[ PAVCX ]
		B34	VHD2281	SCREW	1	[ PAVCX ]
		B36	XQN16+BJ4FN	SCREW	1	[ PAVCX ]
		B37	XQN16+BJ4FN	SCREW	1	[ PAVCX ]
		B38	VHD1870	SCREW	1	[ PAVCX ]
		B39	VHD2252	SCREW	1	[ PAVCX ]
		B40	VHD2252	SCREW	1	[ PAVCX ]
		B41	VHD2252	SCREW	1	[ PAVCX ]
		B42	VHD2409	SCREW	1	[ PAVCX ]
		B43	XQN16+BJ4FN	SCREW	1	[ PAVCX ]
		B44	VHD1870	SCREW	1	[ PAVCX ]
		B45	VHD1870	SCREW	1	[ PAVCX ]
		B46	VHD2039	SCREW	1	[ PAVCX ]
		B47	VHD2150	SCREW	1	[ PAVCX ]
		B48	VHD2150	SCREW	1	[ PAVCX ]
		B49	XQN16+BJ4FN	SCREW	1	[ PAVCX ]
		100	VXW1531	LENS UNIT (W/O MOS)	1	
		101	VXP3823	1ST LENS FRAME UNIT	1	
		102	VXP3824	2ND LENS FRAME UNIT	1	
		103	VXQ2295	MIDDLE FRAME UNIT	1	
		104	L6HAYYYD0056	FOCUS MOTOR UNIT	1	
		105	VMC2225	CAM FRAME SPRING	1	
		106	VXP3825	3RD LENS FRAME UNIT	1	
		107	VXP3828	4TH LENS FRAME UNIT	1	
		108	VXP3830	5TH LENS FRAME UNIT	1	
		109	VDW2567	CAM FRAME	1	
		110	L6DAYYYC0005	ZOOM MOTOR	1	
		111	VXQ2296	MASTER FLANGE UNIT	1	
		112	VEK0T33	LENS FLEX UNIT	1	
		113	VMB4205	TILT SPRING	1	
		114	VMB4205	TILT SPRING	1	
		115	VEK0T48	MOS UNIT	1	E.S.D.
		B101	VHD1974	SCREW	1	
		B102	VHD1974	SCREW	1	
		B103	VHD2109	SCREW	1	
		B104	VHD1974	SCREW	1	
		B105	VHD1974	SCREW	1	
		B106	VHD2109	SCREW	1	
		B107	VHD2109	SCREW	1	
		B108	VHD1974	SCREW	1	
		B109	VHD1974	SCREW	1	
		B110	VHD1974	SCREW	1	
		B111	VHD2351	SCREW	1	
		B112	VHD2351	SCREW	1	

## Model No. : DMC-FZ200 Parts List

Change	Safety	Ref. No.	Part No.	Part Name & Description	Q'ty	Remarks
		B113	VHD2351	SCREW	1	
		B114	VHD2351	SCREW	1	
	⚠	200	-----	BATTERY	1	
	⚠	201	DE-A79BB	BATTERY CHARGER	1	P,PC
	⚠	201	DE-A80AC	BATTERY CHARGER	1	PU,EG,EP,EF,EB,EE,GN
	⚠	201	DE-A80BD	BATTERY CHARGER	1	GC,GK
	⚠	201	DE-A80DA	BATTERY CHARGER	1	SG
	⚠	201	DE-A80CB	BATTERY CHARGER	1	GT
		202	K1HY08YY0025	USB CONNECTION CABLE	1	
		203	VFC4453	SHOULDER STRAP	1	
		204	VYQ5607	LENS CAP UNIT	1	
		205	VYQ7878	LENS HOOD UNIT	1	
		206	VPF1166	CAMERA BAG	1	
		207	VPK5409	PACKING CASE	1	EXCEPT GK
		207	VPK5412	PACKING CASE	1	GK
		208	VPN7421	CUSHION	1	
	⚠	210	VFF1045	CD-ROM (INSTRUCTION BOOK)	1	P,PC,PU
	⚠	210	VFF1046	CD-ROM (INSTRUCTION BOOK)	1	EG,EP,EF,EB
	⚠	210	VFF1047	CD-ROM (INSTRUCTION BOOK)	1	EE
	⚠	210	VFF1048	CD-ROM (INSTRUCTION BOOK)	1	GC,SG,GN
	⚠	210	VFF1049	CD-ROM (INSTRUCTION BOOK)	1	GT
	⚠	210	VFF1050	CD-ROM (INSTRUCTION BOOK)	1	GK
		211	VPF1230	BAG, POLYETHYLENE	1	
	⚠	212	VQT4H46	BASIC O/I (ENGLISH/SPANISH)	1	P
	⚠	212	VQT4H47	BASIC O/I (ENGLISH/CANADIAN FRENCH)	1	PC
	⚠	212	VQT4H48	BASIC O/I (SPANISH/PORTUGUESE)	1	PU
	⚠	212	VQT4H49	BASIC O/I (GERMAN/TURKISH)	1	EG
	⚠	212	VQT4H50	BASIC O/I (ITALIAN/DUTCH)	1	EG
	⚠	212	VQT4H51	BASIC O/I (SPANISH/PORTUGUESE)	1	EG
	⚠	212	VQT4H52	BASIC O/I (FRENCH)	1	EG,EF
	⚠	212	VQT4H53	BASIC O/I (SWEDISH/DANISH)	1	EP
	⚠	212	VQT4H54	BASIC O/I (POLISH/CZECH)	1	EP
	⚠	212	VQT4H55	BASIC O/I (HUNGARIAN/FINNISH)	1	EP
	⚠	212	VQT4H57	BASIC O/I (ENGLISH)	1	EB
	⚠	212	VQT4H58	BASIC O/I (RUSSIAN/UKRAINIAN)	1	EE
	⚠	212	VQT4H59	BASIC O/I (ENGLISH/CHINESE(TRADITIONAL))	1	GC,SG
	⚠	212	VQT4H60	BASIC O/I (ARABIC/PERSIAN)	1	GC
	⚠	212	VQT4H61	BASIC O/I (VIETNAMESE)	1	GC
	⚠	212	VQT4J57	BASIC O/I (CHINESE(TRADITIONAL))	1	GT
	⚠	212	VQT4H62	BASIC O/I (CHINESE(SIMPLIFIED))	1	GK
	⚠	212	VQT4H63	BASIC O/I (ENGLISH)	1	GN
		213	VFF1023-E	CD-ROM(SOFT)	1	EXCEPT GK See "Notes"
		213	VFF1024-E	CD-ROM(SOFT)	1	GK See "Notes"
		214	VQL2C67-2	OPERATING LABEL	1	PC
		214	VQL2C68-1	OPERATING LABEL	1	GT
	⚠	215	K2CA2CA00025	AC CORD W/PLUG	1	PU
	⚠	215	K2CQ2YY00082	AC CORD W/PLUG	1	EG,EP,EF,EE,GC
	⚠	215	K2CT3YY00034	AC CORD W/PLUG	1	EB,GC
	⚠	215	K2CA2YY00247	AC CORD W/PLUG	1	SG
	⚠	215	K2CA2YY00129	AC CORD W/PLUG	1	GT
	⚠	215	K2CA2YY00130	AC CORD W/PLUG	1	GK
	⚠	215	K2CJ2YY00052	AC CORD W/PLUG	1	GN